

OLIVARI



AC LEIGH

ARCHITECTURAL IRONMONGERS
SECURITY SPECIALISTS

Since 1911 Olivari has been manufacturing handles at its own factories in Italy where the entire production process takes place. Starting with brass billets, the handles are forged, milled, polished, buffed, chrome-plated and hallmarked with a laser.

Olivari has attained ISO 9001 and ISO 14001 certifications.

Though it uses the most advanced technology, Olivari preserves all the artisanal wisdom it has accumulated in 100 years of history.

OLIVARI 



BBPR_Torre Velasca_Milano_Italia_1958 ph Stefano Petroni

A hundred years of Olivari door handles

In its century-old history, Olivari has always sought out the maximum in quality, relying on the creativity of the best designers and architects. The Olivari family has handed down its attention to details, the search for innovation, and mainly a passion for its work, from generation to generation.

Battista Olivari founds the company in 1911 in Borgomanero, in the province of Novara; its plants are still there and its handles are entirely manufactured there. In 1926, Battista is succeeded by his wife Antonietta Ramelli, one of the few women directing a company at the time. In the 1930s, the first collaboration with architects begins with Marcello Piacentini and Gio Ponti, two of the important Italian architects of the era.

After World War II the company passes to the hands of the brothers Ernesto, Ambrogio, and Luigi. Olivari helps post bellum reconstruction by working side by side not only with Gio Ponti, who designs a classic handle like Lama, but with architects of the stature of Franco Albini, Ignazio Gardella, Angelo Mangiarotti, Caccia Dominioni, and BBPR as well. These designers create superbly handsome custom handles for their buildings. Then the designs stay in the Olivari catalog; some of them are still being manufactured.

Starting in the 1960s, Olivari is looking for new designs, and decides to call on the leading exponents of Italian design such as Sergio Asti, Marcello Nizzoli and Joe Colombo. At the same time it never stops following evolutions in technology: in 1959 it markets

Bica, the world's first anodized aluminum handle. In 1970 it introduces Boma, the first colored plastic handle. They both quickly become widely copied best-sellers.

In the 1980s, the company is handed down to the third generation of the Olivari family and the company goes international. New designers are summoned: Giogetto Giugiaro, Ferdinand A. Porsche, Rodolfo Bonetto, and Giotto Stoppino, who wins the Italian Golden Compass design award with his handle Alessia.

The following decade is marked by profitable collaboration with Alessandro Mendini, the company's art director who rethinks the corporate image. This is how handles by Paolo Portoghesi, Oscar Tusquets, Vico Magistretti, Andrea Branzi, and Massimo Iosa Ghini come into the company.

In the oughts, the manufacturing system is highly automated and environmentally friendly. The Biochrome finish and SuperFinish are introduced. Rodolfo Dordoni, James Irvine, Piero Lissoni, and Patricia Urquiola are just a few of the designers involved, not to mention leaders in contemporary architecture: Shigeru Ban, Steven Holl, Toyo Ito, Daniel Libeskind and Dominique Perrault.

At the beginning of the year two thousand and ten, contemporary designers and architects such as Stefano Giovannoni, Patricia Urquiola, Jean Nouvel and Daniel Libeskind express themselves with different languages and create minimal sculpted, ergonomic, ironic handles.

2014 has just started and the research by Olivari continues...

Toyo Ito_Suites Avenue_Barcelona_Spain_2000





Componenti basse

Flat hardware, important details

Olivari's innovative thin escutcheon and rosette is only 1/5 inch (5 mm) thick, half the traditional thickness. The return spring is still installed inside, so this thinner device can be assembled on any door.

It definitely looks better: the immobile parts stand out less and the handle's lines stand out more.

The thin escutcheon was conceived especially for Arc, Beta, Ice Cube, Living, Moon, and Planet lever handles, and for the Diana and Link knobs. However it is compatible with all the other Olivari models with a round or square escutcheon.

Olivari has patented this flat hardware.

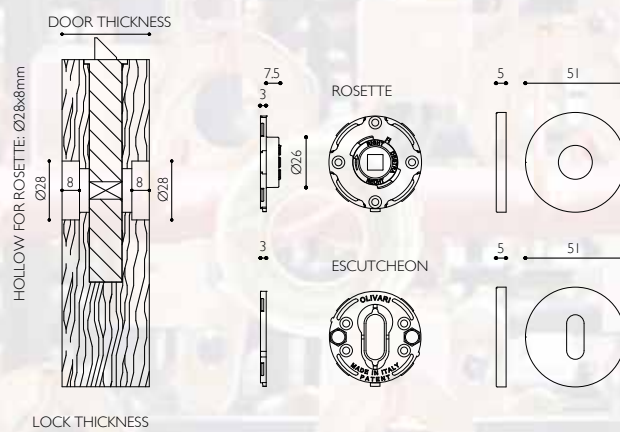
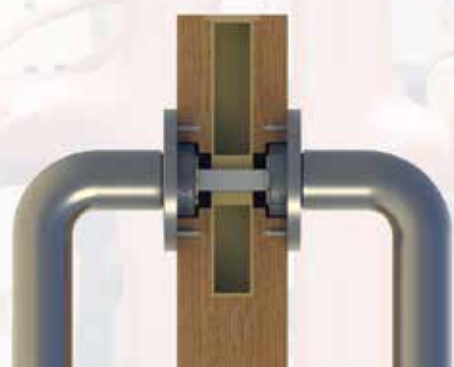



ISO 9001 certified quality management

Olivari has implemented a quality management system that attained UNI EN ISO 9001 certification no. 0929/05. All its handles are manufactured entirely within the company. Each manufacturing phase is directly controlled in Olivari's Borgomanero (NO) Italy plant.

ISO 14001 certified environmental management

Olivari has obtained UNI EN ISO 14001 Certificate no. 0308A/1. This acknowledges that the company's environmental management not only complies with all regulations, but that the entire manufacturing process is continuously monitored to avoid any kind of pollution.



Finishes

Varnished



P	P/S	S
Polished	Polished / Satin	Satin

P – Polished

This polished finish brings out all the beauty of natural brass; it is glazed with a transparent lacquer that prevents tarnishing and maintains its color.

S – Satin

Brass attains consistency and acquires a classic tone with a mechanical satin finish. Protective lacquer maintains the natural color of the brass over time.

Chrome



C	C/MC	MC
Chrome	Chrome / Matt Chrome	Matt Chrome

C – Chrome

The brass handle is plated with a metal layer that protects it from wear and tear and the environment. The bright silver color is typical of chrome-plating, suitable for elegant rooms.

MC – Matt chrome

This finish is obtained by mechanically milling the brass surface prior to chrome-plating it. The result is a tonality and feel that lend it for use in modern architectural settings.

Biochrome®



BP

Biochrome®
Polished

BS

Biochrome®
Satin

BP – Biochrome® Polished

This finish is obtained with low environmental impact chrome-plating. The handles are certified for use in green architecture and have been hallmarked with a laser serial number. The color is darker than traditional chrome, without its blue cast.

BS – Biochrome® Satin

Biochrome® finish characteristics are obtained by plating the chrome on a milled brass base to give the surface a satin finish. The handles have been laser hallmarked with the BIO logo; their serial number makes them easy to trace.

SuperFinish®



SGP

Super Gold
Polished

SNS

Super Nickel
Satin

SSSS

Super Stainless
Steel Satin

SGP – Super Gold Polished

This finish is the same color as polished brass, but with extraordinary resistance to wear and tear and the most hostile agents: humidity, salinity, temperature changes and ultraviolet rays. This is recommended for outdoors and high traffic settings.

SNS – Super Nickel Satin

Super Nickel provides the elegant color of nickel without the risk of allergenic reactions. Like everything in Olivari's SuperFinish® range, this finish is right for external settings and public buildings, thanks to its extraordinary resistance and durability.

SSSS – Super Stainless Steel Satin

This finish has the typical light silver color of stainless steel although its surface resists longer than steel. It offers all the typical characteristics of SuperFinish® products



Biocromo®

BIOCHROME® is an exclusive Olivari finish that protects the environment.

In 2005, Olivari's Research and Development Department develops a unique method for chrome-plating brass ecologically. Unlike the traditional manufacturing process, the BIOCHROME® covering uses trivalent chrome instead of the common hexavalent chrome, harmful to both health and the environment.

Our BIOCHROME® finish is suitable for green architecture and anywhere a low environmental impact product is required.

Laboratory tests have shown that the greater thickness and uniformity of the BIOCHROME® plating over traditional chrome-plating guarantee great resistance to wear and tear and tamishing.

Biochrome-plated products are recognizable because they have been laser hallmarked with the BIO logo. Every single handle can be traced because it provides the lot number and date of manufacture.



Superfinish®

SUPERFINISH® is guaranteed to last for 30 years; it is exceptionally resistant.

This is obtained by plating metal with exceptional characteristics on a brass titrate alloy base.

It will stand up to corrosive settings and external agents: salt spray, humidity, acid rain, the sun, and extreme temperatures. It is especially suited for use outdoors, in marine areas, and high traffic zones such as hotels and public buildings.

SUPERFINISH® has UNI and ISO certification for resistance to ultraviolet rays, standing up to salt spray for a good 3,000 hours. SUPERFINISH®'s extraordinary hardness has been tested at the Padua National Research Center. Laboratory tests demonstrate its resistance to solvents and prolonged contact with silicon, lime, cement, lime scale build-up products, alcohol, hydrogen peroxide, ammonia and muriatic acid.

All SUPERFINISH® products can be recognized by their indelible OLIVARI laser hallmark. Every single handle can be traced: the lot and date of production have been written on it.

Total

Rodolfo Dordoni 2007

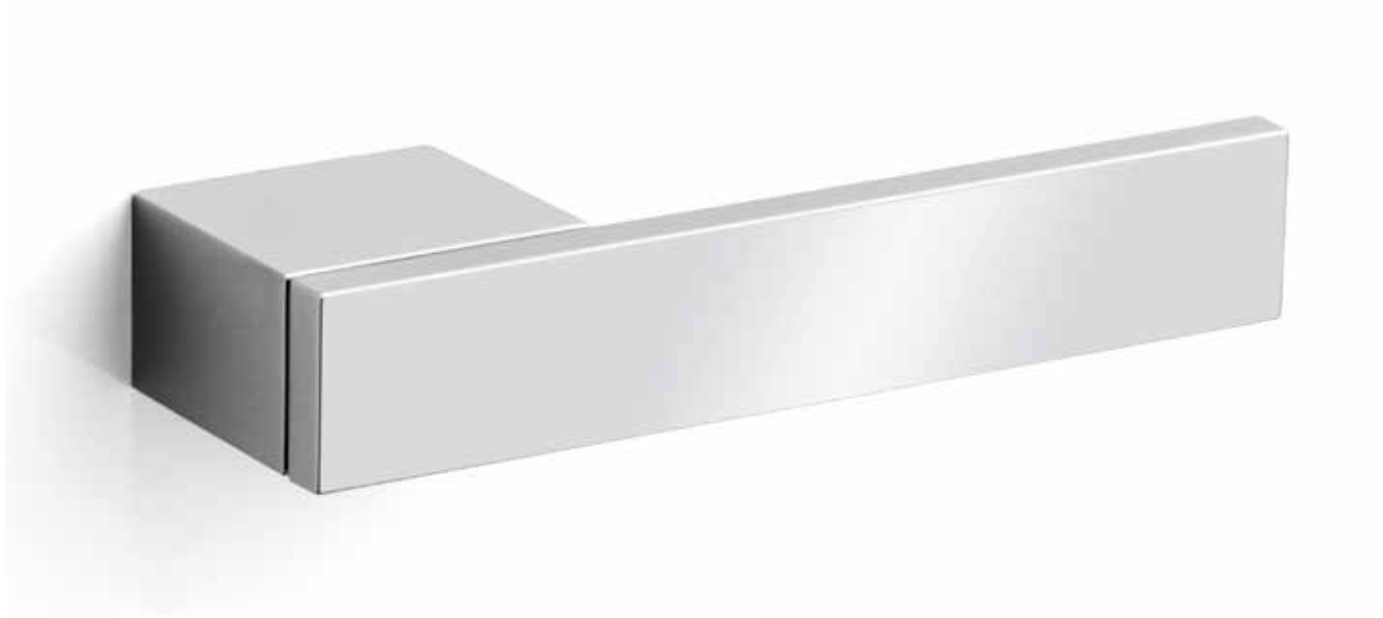

Sometimes revolutions happen with the maximum in simplicity like Total, the first door handle without a rosette. The entire mechanism is contained in its pure, impeccable form, perfectly proportioned by Rodolfo Dordoni.

M207

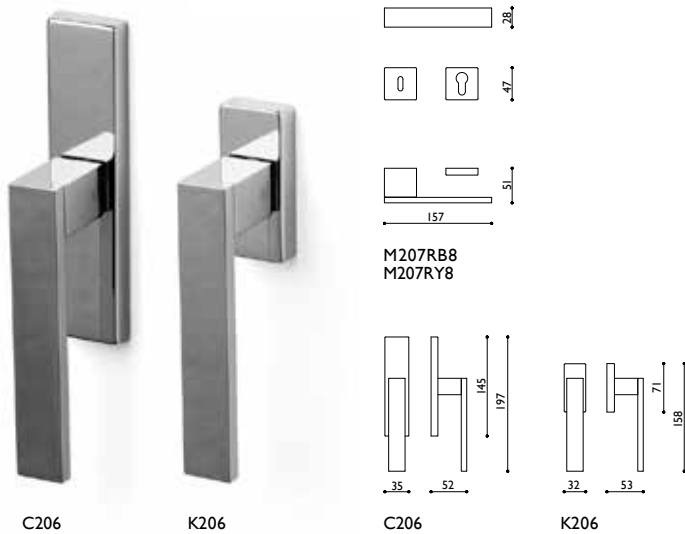

Brass



BP Biochrome Polished



MC Matt Chrome



SSSS Super Stainless Steel Satin

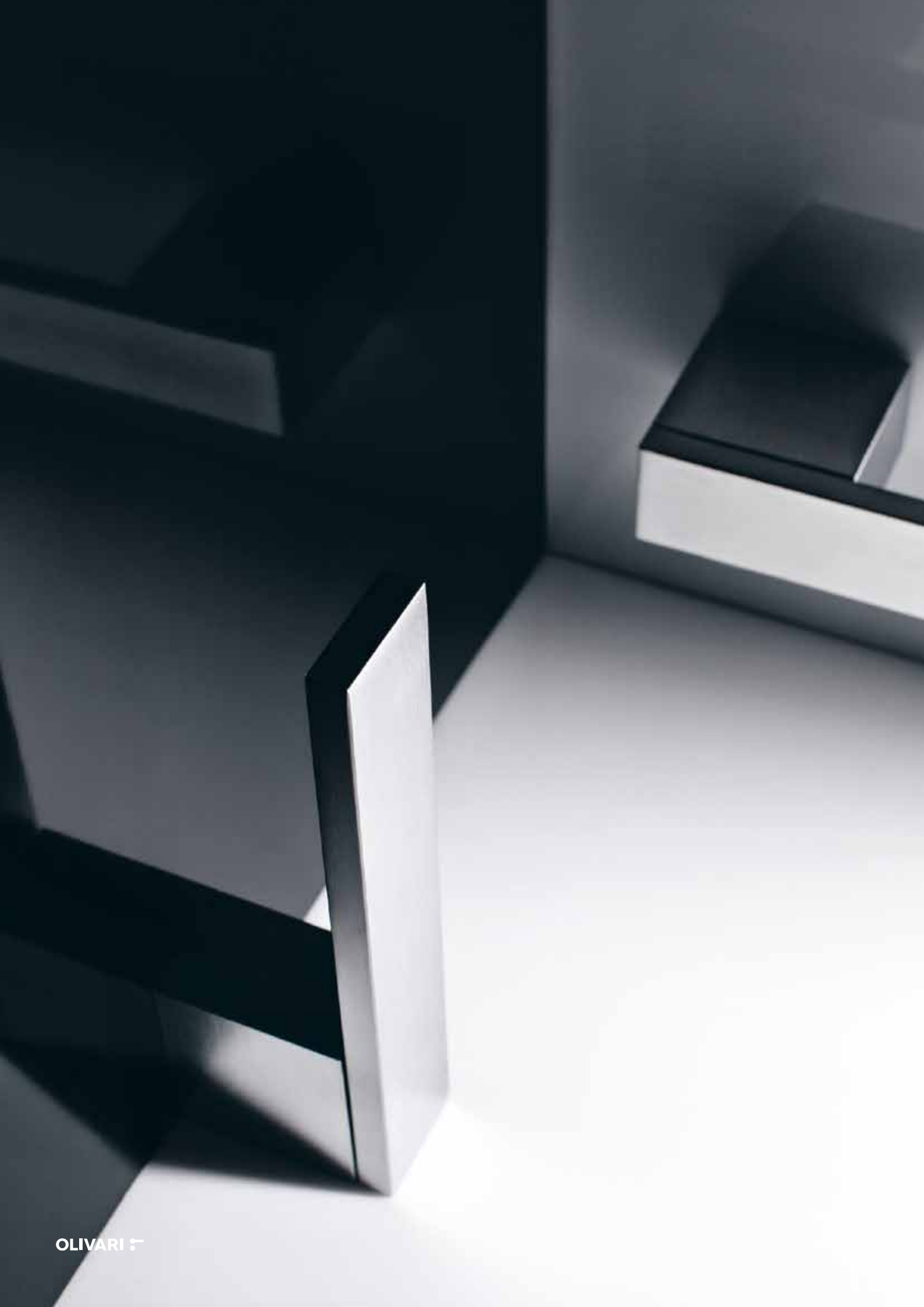

Lotus Q
Javier Lopez 2014



M241 B



C241



K241B

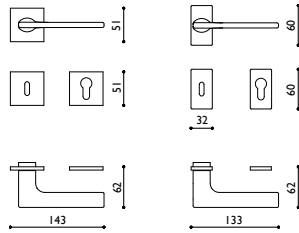

M241RB8B
M241RY8B

M241VB8B
M241VY8B

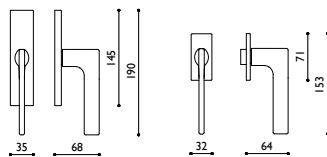

C241

K241B

Brass



C Chrome



MC Matt Chrome



SSSS Super Stainless Steel Satin

Pitagora Q
Giorgetto Giugiaro 2014



M240B



C240

K240B

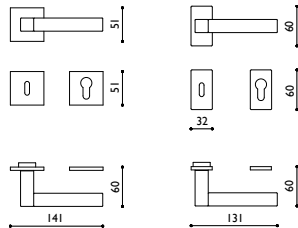

M240RB8B
M240RY8B

M240VB8B
M240VY8B

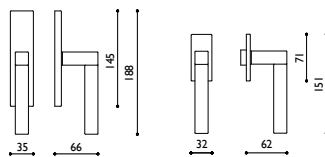

C240

K240B

Brass



C Chrome



C/MC Chrome/Matt Chrome



MC Matt Chrome



SSSS Super Stainless Steel Satin

Trend

Studio Olivari 2012



M228 B



<p>C228</p>	<p>K228B</p>	<p>C228</p>	<p>K228B</p>	<p>Brass</p> <p>C Chrome</p> <p>MC Matt Chrome</p> <p>SSSS Super Stainless Steel Satin</p>
-------------	--------------	-------------	--------------	---------------------------------------------------------------------------------------------------

Diana

Studio Olivari 2007



M206



C206



K206

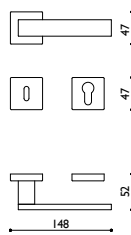

M206RB8
M206RY8

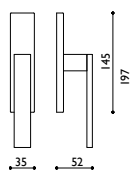

C206

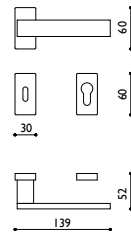

M206VB8
M206VY8

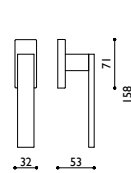

K206

Brass



BP Biochrome Polished



MC Matt Chrome



SSSS Super Stainless Steel Satin

Adamant

Patricia Urquiola 2008



M216



C216



K216

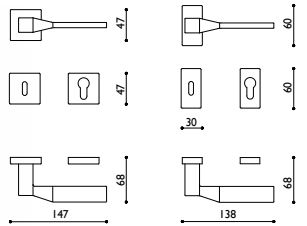

M216RB8
M216RY8

M216VB8
M216VY8

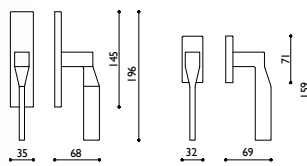

C216

K216

Brass



BP Biochrome Polished



MC Matt Chrome



Denver

Daniel Libeskind 2009

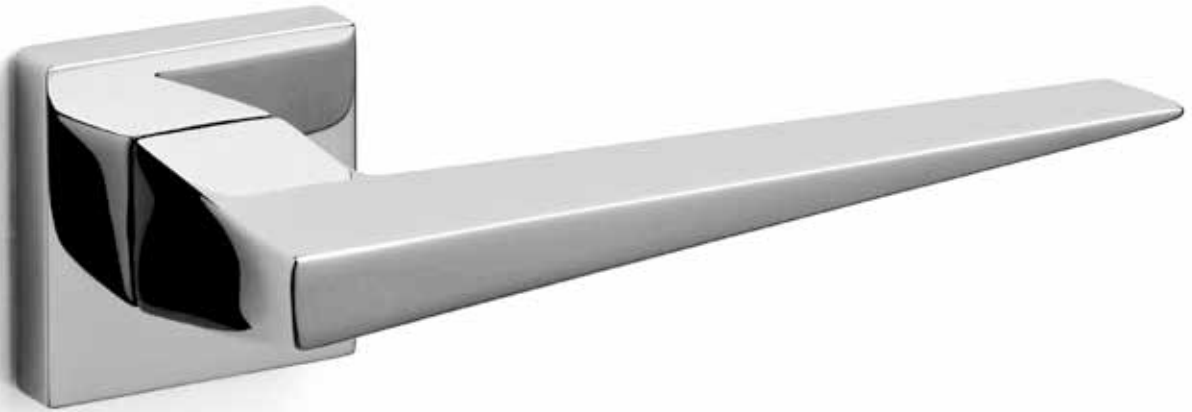

M218



C218



K218

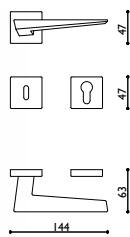

M218RB8
M218RY8

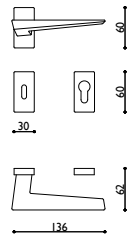

M218VB8
M218VY8

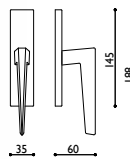

C218

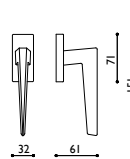

K218

Brass



C Chrome



MC Matt Chrome



SSSS Super Stainless Steel Satin

Sky

Claudio Bellini 2008



M214



C214



K214

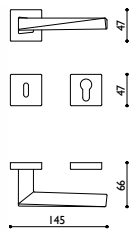

M214RB8
 M214RY8

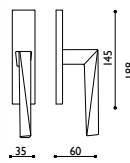

C214

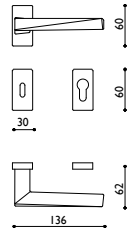

M214VB8
 M214VY8

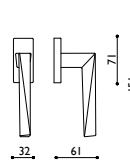

K214

Brass



BP Biochrome Polished



MC Matt Chrome

Arc

Rodolfo Dordoni 2010



M225 B



C225

K225B

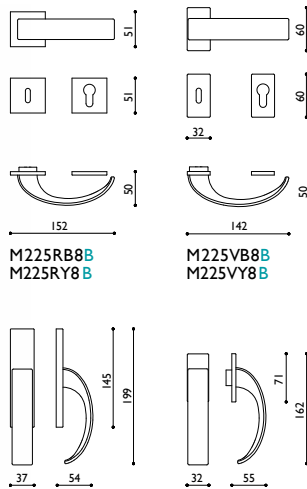

M225RB8B
 M225RY8B

M225VB8B
 M225VY8B

C225

K225B

Brass



C Chrome



MC Matt Chrome



Nina

Daniel Libeskind 2013

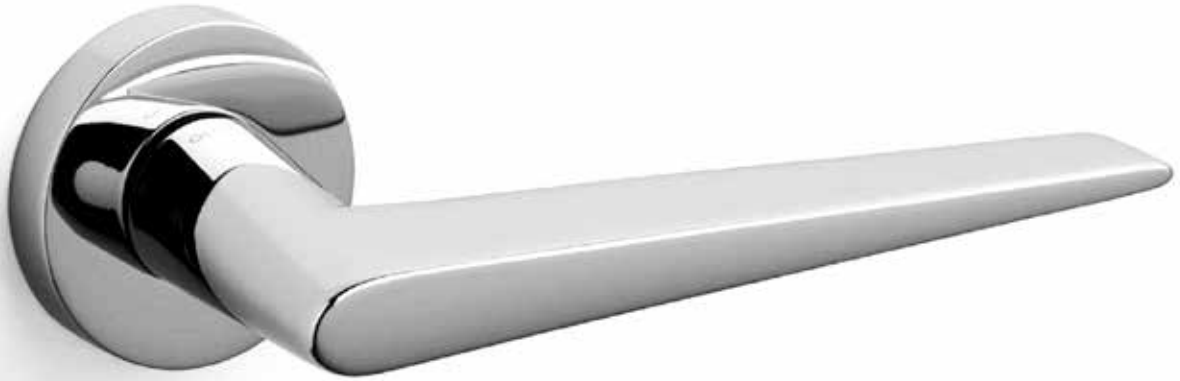

M234

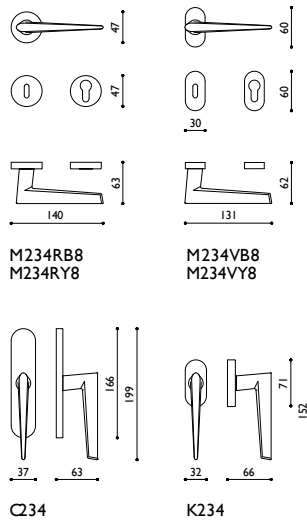

Brass



C Chrome

MC Matt Chrome

SSSS Super Stainless Steel Satin

Lama

Gio Ponti 1954



M107



C107



K107

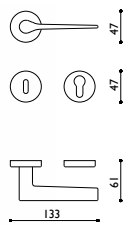

M107RB8
M107RY8

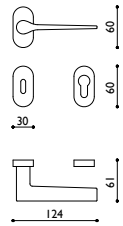

M107VB8
M107VY8

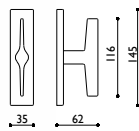

C107

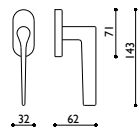

K107

Brass



P Polished
SGP Super Gold Polished



C Chrome



MC Matt Chrome



SSSS Super Stainless Steel Satin

Ala

Massimo Iosa Ghini 2009



M215



C215

K215

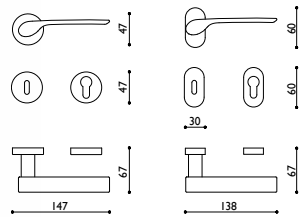

M215RB8
M215RY8

M215VB8
M215VY8

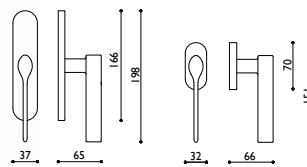

C215

K215

Brass



BP Biochrome Polished



MC Matt Chrome



SNS Super Nickel Satin

Fin

Toyo Ito 2009



M217



Q217



K217

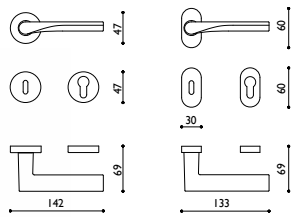

M217RB8
M217RY8

M217VB8
M217VY8

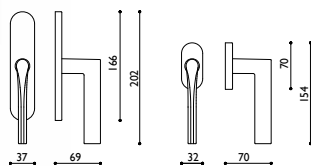

Q217

K217

Brass



BP Biochrome Polished



MC Matt Chrome



SNS Super Nickel Satin

Space

Alessandro Mendini 2004



M193



C192



K192

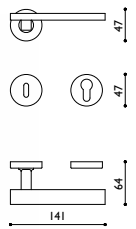

M193RB8
M193RY8

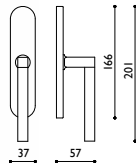

C192

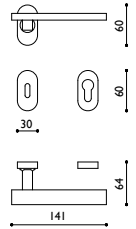

M193VB8
M193VY8

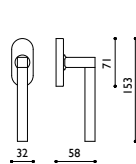

K192

Brass



P/S Polished/Satin
 SG Super Gold Polished/Satin



C/MC Chrome/Matt Chrome



MC Matt Chrome



SS Super Stainless Steel Satin



Selene

Massimo Iosa Ghini 2005



M194



C194



K194

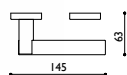

M194RB8
M194RY8

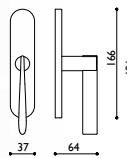

C194

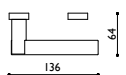

M194VB8
M194VY8

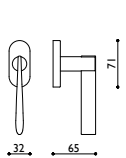

K194

Brass



P/S Polished/Satin

SG Super Gold Polished/Satin



C/MC Chrome/Matt Chrome



MC Matt Chrome

Beta

Joe Colombo 2010



M221 B



C221



K221 B

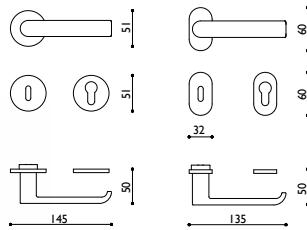

M221 RB8B
M221 RY8B

M221 VB8B
M221 VY8B

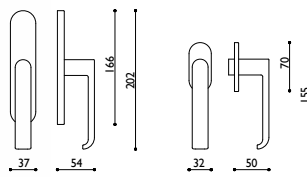

C221

K221 B

Brass



C Chrome



MC Matt Chrome



SSSS Super Stainless Steel Satin

Radial

Rodolfo Dordoni 2014



M235



C235



K235

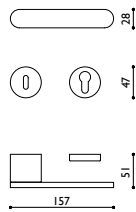

M235RB8
M235RY8

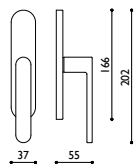

C235

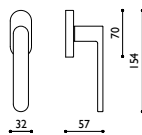

K235

Brass



C Chrome Plated



MC Matt Chrome Plated



S Stainless Steel Satin

Link

Piero Lissoni 2006



M200



C200

K200

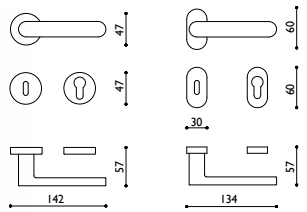

M200RB8
M200RY8

M200VB8
M200VY8

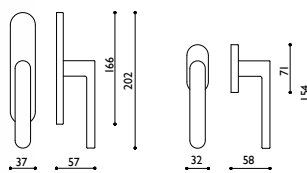

C200

K200

Brass



BP Biochrome Polished



MC Matt Chrome



SSSS Super Stainless Steel Satin

Planet

Luca Casini 2005



M195



C195



K195

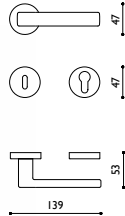

M195RB8
M195RY8

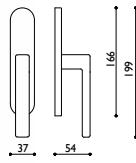

C195

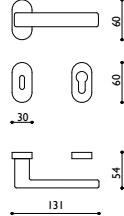

M195VB8
M195VY8

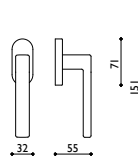

K195

Brass



SGP Super Gold Polished



C Chrome



MC Matt chrome



SNS Super Nickel Satin



SSSS Super Stainless Steel Satin



OLIVARI

Logo

James Irvine 2006



M197



C197

K197

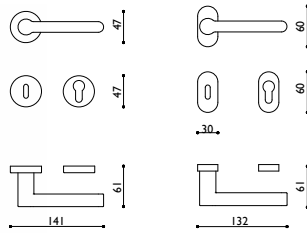

M197RB8
M197RY8

M197VB8
M197VY8

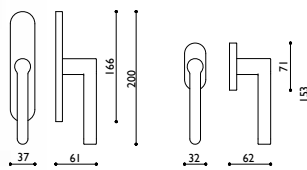

C197

K197

Brass



BP Biochrome Polished



MC Matt Chrome



SSSS Super Stainless Steel Satin

Laser

Richard Sapper 1998



M176



CI76

KI76

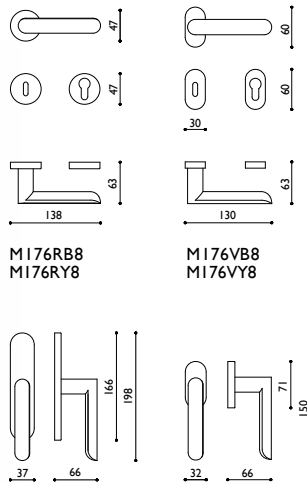

M176RB8
M176RY8

M176VB8
M176VY8

CI76

KI76

Brass



SGP Super Gold Polished



C Chrome



MC Matt Chrome



SSSS Super Stainless Steel Satin

Madison

Luca Casini 2005



M196



C196

K196

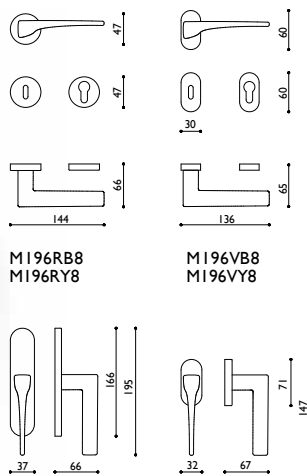

M196RB8
M196RY8

M196VB8
M196VY8

C196

K196

Brass



C Chrome



MC Matt Chrome



SNS Super Nickel Satin

Time

Alessandro Mendini 2004



M192



C192



K192

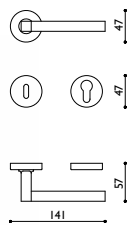

M192RB8
M192RY8

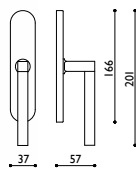

C192

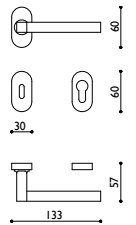

M192VB8
M192VY8

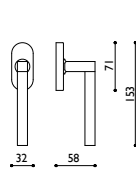

K192

Brass



SG Super Gold Polished/Satin



CA Chrome/Matt Chrome



MCW Matt Chrome/Wengé



MC Matt Chrome



SSSS Super Stainless Steel Satin

Lotus

Javier Lopez 2014



M238B



C238



K238B

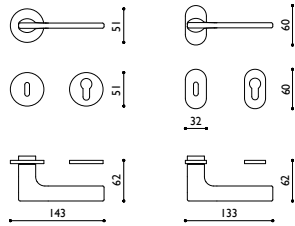

M238RB8B
M238RY8B

M238VB8B
M238VY8B

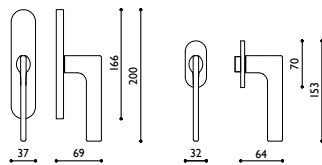

C238

K238B

Brass



C Chrome



MC Matt Chrome



SSSS Super Stainless Steel Satin

Alexandra

F.A. Porsche 1989



M150



C150

K150

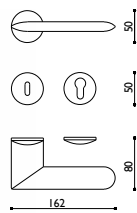

M150RB8
 M150RY8

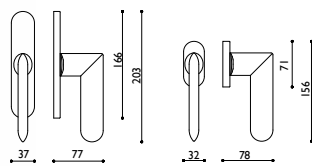

C150

K150

Brass



C Chrome



MC Matt Chrome



SSSS Super Stainless Steel Satin

Stilo

Enzo Mari 2003

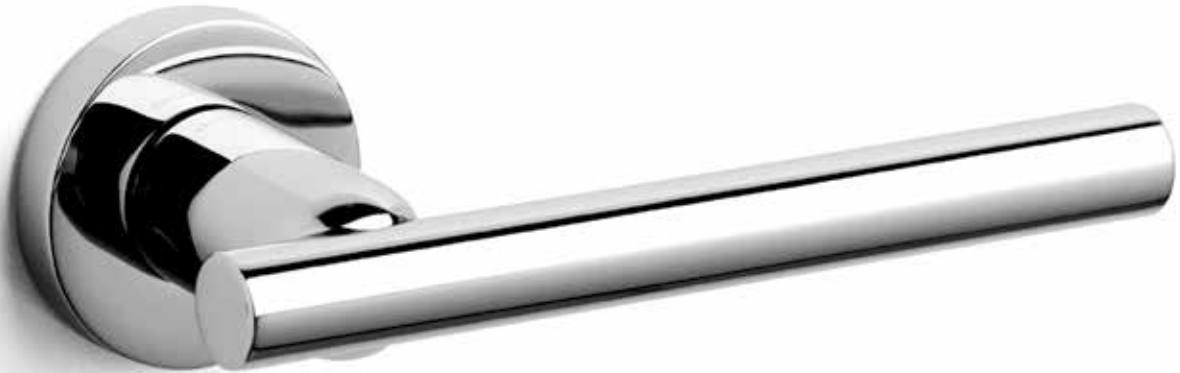

M190



CI 90



KI 90

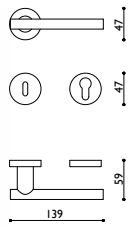

M190RB8
M190RY8

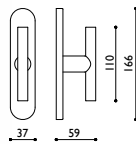

CI 90

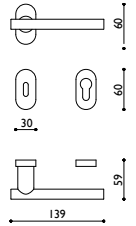

M190VB8
M190VY8

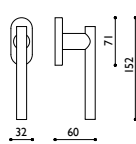

KI 90

Brass



SGP Super Gold Polished



C Chrome



MC Matt Chrome



SSSS Super Stainless Steel Satin

Stilo breaks down the handle into its three basic elements: lever, rosette, and spindle. Enzo Mari rejected all formalisms and concentrated on the manufacturing it with lathe work instead of forging, in order to obtain a perfect mechanism.



Beijing

Steven Holl 2008

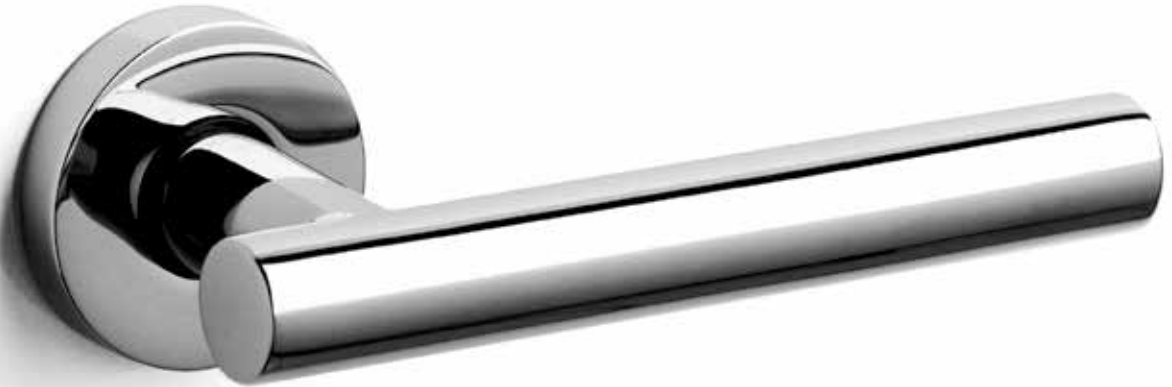

M208



C208

K208

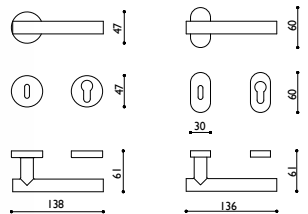

M208RB8
M208RY8

M208VB8
M208VY8

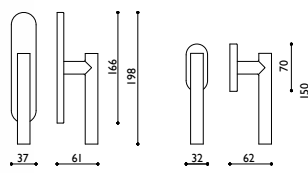

C208

K208

Brass



BP Biochrome Polished



MC Matt Chrome
BS Biochrome Satin



SSSS Super Stainless Steel Satin

San Babila

Luigi Caccia Dominioni 1968



M119



CI19

KI19

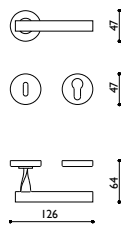

M119RB8
M119RY8

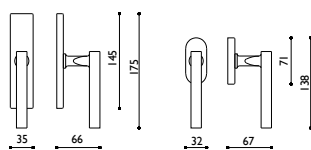

CI19

KI19

Brass



C Chrome



MC Matt Chrome

Sibilla

Vico Magistretti 1992

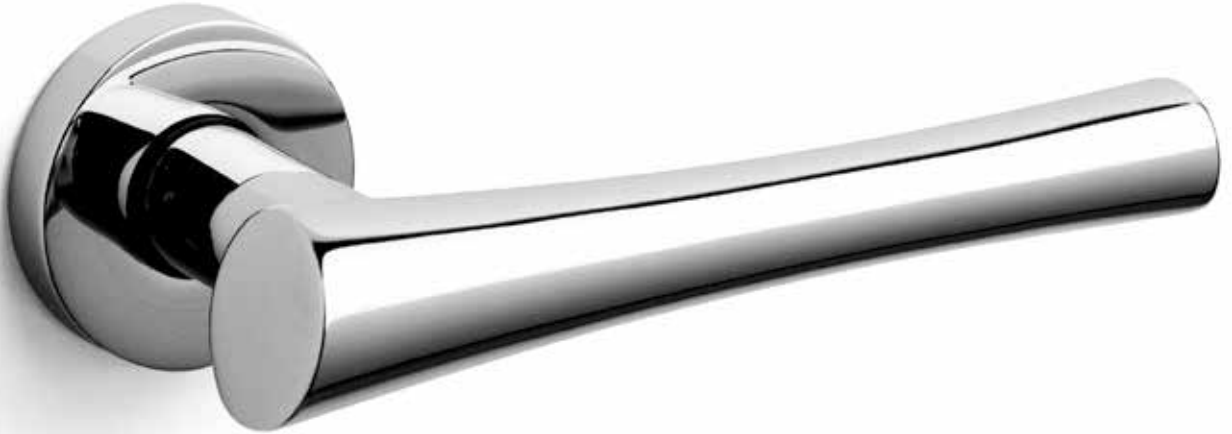

M154



C154

K154

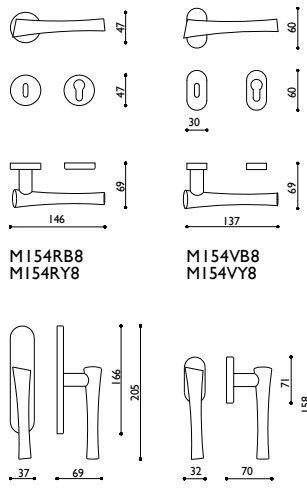

C154

K154

Brass



ZL Super Gold Polished



C Chrome



MC Matt Chrome



Aurelia

Penta Associati 2002



M185



C185



K185

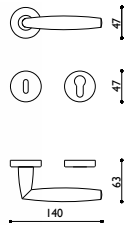

M185RB8
M185RY8

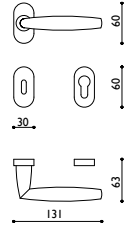

M185VB8
M185VY8

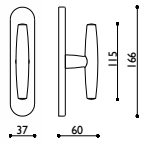

C185

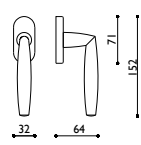

K185

Brass



P Polished
SGP Super Gold Polished



S Satin



C Chrome



MC Matt Chrome



SNS Super Nickel Satin



SSSS Super Stainless Steel Satin

Euclide

Nicola Novelletto 2012



M229B

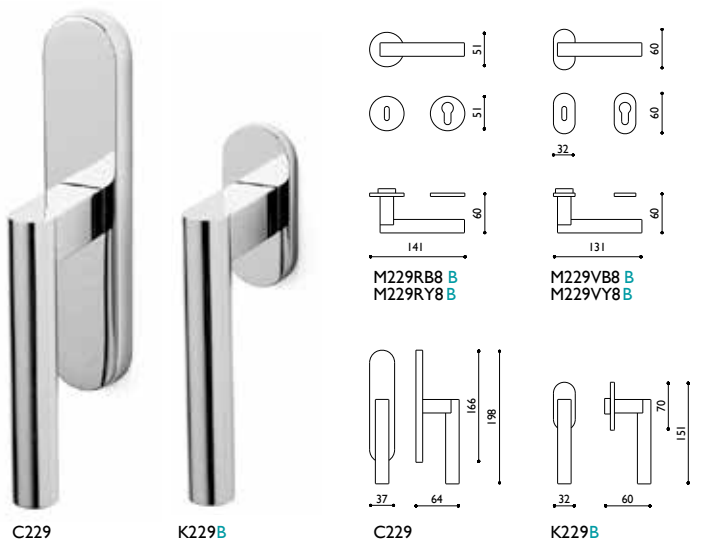

Brass



C Chrome



MC Matt Chrome

Sector

Penta Associati 2002



M186

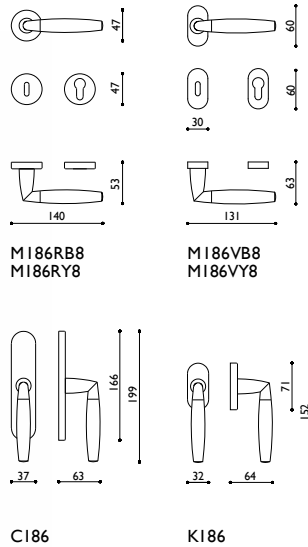

Brass



P/S Polished/Satin
SG Super Gold Polished/Satin



C/MC Chrome/Matt Chrome



C/SNS Chrome/Super Nickel Satin



Pitagora

Giorgetto Giugiaro 2014



M239B



C239



K239B

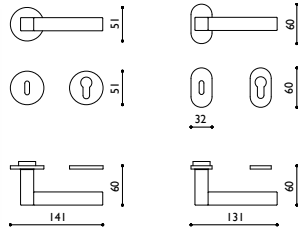

M239RB8B
M239RY8B

M239VB8B
M239VY8B

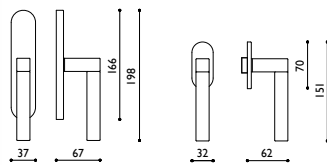

C239

K239B

Brass



C Chrome



C/MC Chrome/Matt Chrome



CO Matt Chrome



SSSS Super Stainless Steel Satin

Chelsea

Jean Nouvel 2013



M232 B

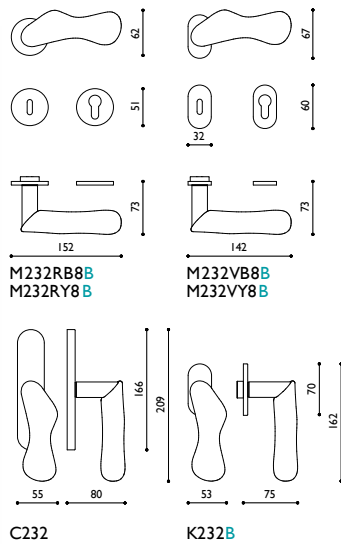

Brass and Porcelain



Globe

Stefano Giovannoni 2012



M227

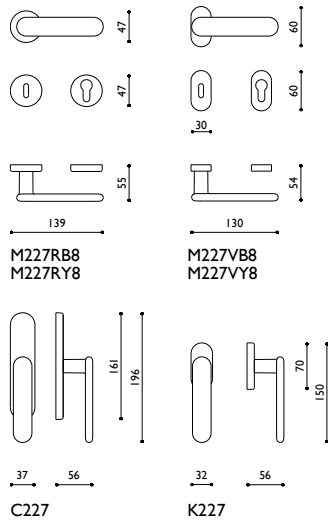

Brass



C Chrome

MC Matt Chrome

SNS Super Nickel Satin

Marbella

Penta Associati 2014



M237B



<p>C237 K237B</p>	<p>M237RB8B M237RY8B M237VB8B M237VY8B</p> <p>C237 K237B</p>	<p>Brass</p> <p>CP Chromium Plated MCP Matt Chromium Plated MS Matt Superinox</p>
------------------------------------------------------	------------------------------------------------------------------------------------------------------------------------------	-----------------------------------------------------------------------------------------------------------------------

Aster

Penta Associati 1998



M174



C174

K174

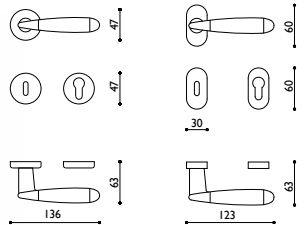

M174RB8
M174RY8

M174VB8
M174VY8

C174

K174

Brass



P/S Polished/Satin

SG Super Gold Polished/Satin



P Polished/Cherry Wood

SGP Super Gold Polished/
Cherry Wood



C/MC Chrome/Matt Chrome



MC Matt Chrome/Cherry Wood

Brass and Polyester

Chrome



9C Matt White



5C Matt Amber



4C Matt Blue



CE Matt Black

Also Available:
Super Gold Polished
Matt Chrome



Tecno

Giorgetto Giugiaro 1999



M182



C182



K182

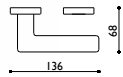
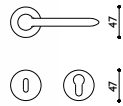

M182RB8
M182RY8

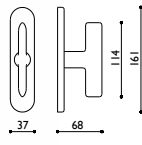

C182

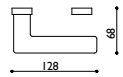
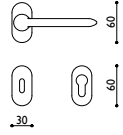

M182VB8
M182VY8

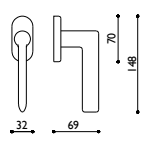

K182

Brass



P Polished
SGP Super Gold Polished



C Chrome



MC Matt Chrome



SNS Super Nickel Satin



SSSS Super Stainless Steel Satin

Futura

Penta Associati 1997

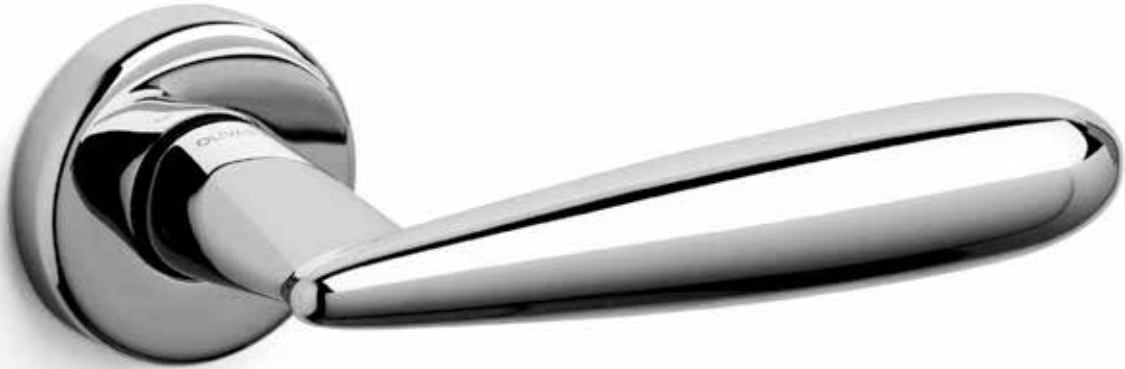

M172



C172



K172

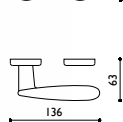
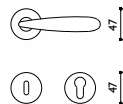

M172RB8
M172RY8

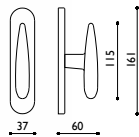

C172

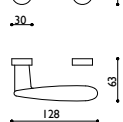
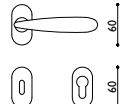

M172VB8
M172VY8

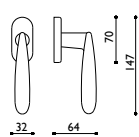

K172

Brass



P Polished
SGP Super Gold Polished



C Chrome



MC Matt Chrome



SNS Super Nickel Satin



SSSS Super Stainless Steel Satin

Wind

Penta Associati 2003



M187



C187



K187

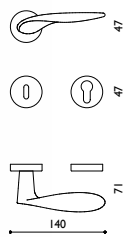

M187RB8
M187RY8

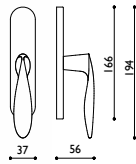

C187

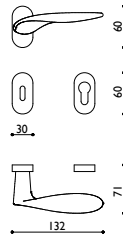

M187VB8
M187VY8

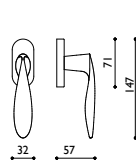

K187

Brass



P Polished
SGP Super Gold Polished



S Satin



C Chrome



MC Matt Chrome



Comet

Nicola Novelletto 2001



M183



C183

K183

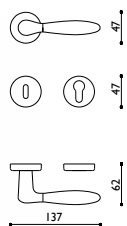

M183RB8
M183RY8

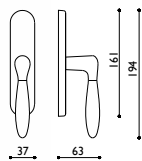

C183

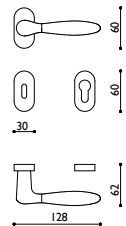

M183VB8
M183VY8

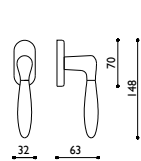

K183

Brass



P/S Polished/Satin
SG Super Gold Polished/Satin



C/MC Chrome/Matt Chrome



C/SNS Chrome/Super Nickel Satin

Lucy

Patricia Urquiola 2012



M231 B



C231



K231 B

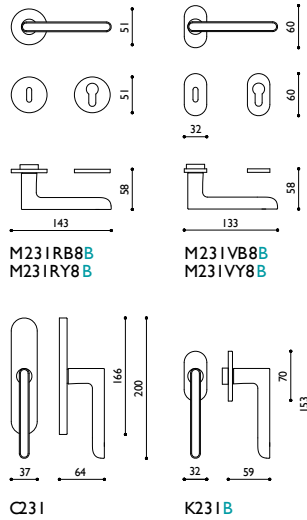

Brass



C Chrome



MC Matt Chrome

Nirvana

Massimo Iosa Ghini 1997



M173



CI73

KI73

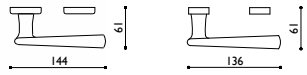
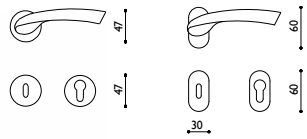

M173RB8
M173RY8

M173VB8
M173VY8

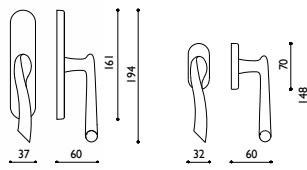

CI73

KI73

Brass



P Polished
SGB Super Gold Polished



C Chrome



MC Matt Chrome

184

OLIVARI



Perla

Penta Associati 2003



M189



CI89



K189

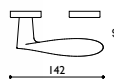

M189RB8
M189RY8

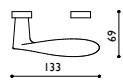

M189VB8
M189VY8

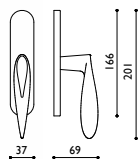

CI89

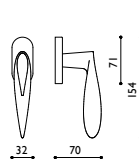

K189

Brass



P Polished
 SGP Super Gold Polished



MC Matt Chrome

Novella

Nicola Novelletto, Roberto Volonterio 1996



M165



C165



K165

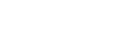
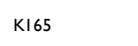
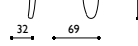
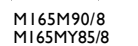
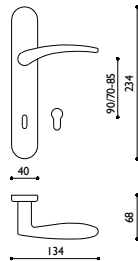
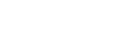
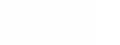
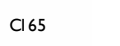
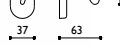
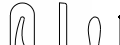
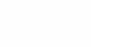
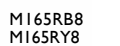
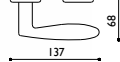
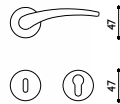

Brass



P Polished
SGP Super Gold Polished



S Satin



C Chrome



MC Matt Chrome



SSSS Super Stainless Steel Satin

Conca

Patricia Urquiola 2014



M236B



C236

K236B

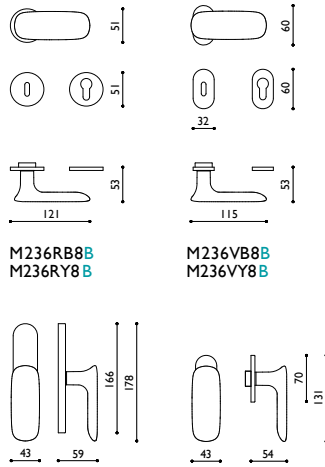

M236RB8B
M236RY8B

M236VB8B
M236VY8B

C236

K236B

Brass



CP Chromium Plated



MCP Matt Chromium Plated



MS Matt Superinox



OLIVARI 

Agata

Franco Albini, Franca Helg 1965



Franco Albini and Franca Helg are masters of design who wanted an Olivari handle as light as a bird's wing or a flower petal. This is the most elegant ergonomic handle, good classic Italian design.

M116



C116

K116

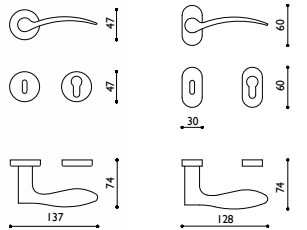

M116RB8
M116RY8

M116VB8
M116VY8

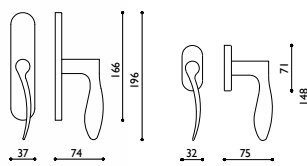

C116

K116

Brass



SGP Super Gold Polished



C Chrome



MC Matt Chrome

Onda

Nicola Novelletto 1998



M175



C175

K175

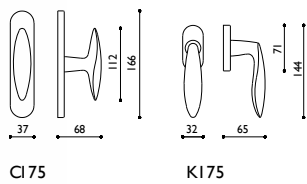
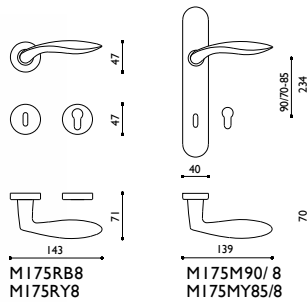

Brass



P Polished
SGB Super Gold Polished



S Satin



C Chrome



MC Matt Chrome



SSSS Super Stainless Steel Satin

Pomoli centrali

Victor Studio Olivari



PI29

Brass

C Chrome
MC Matt Chrome

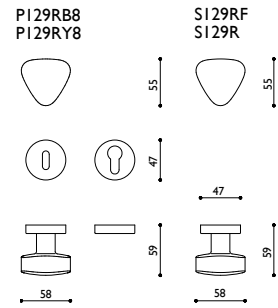

Triangolare Studio Olivari



PI06



Brass

SGP Super Gold Polished
MC Matt Chrome

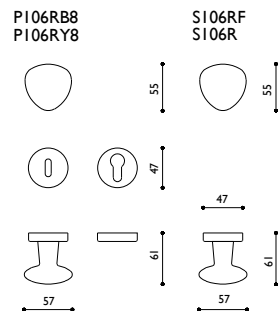

Chiavistelli

Space Q Studio Olivari

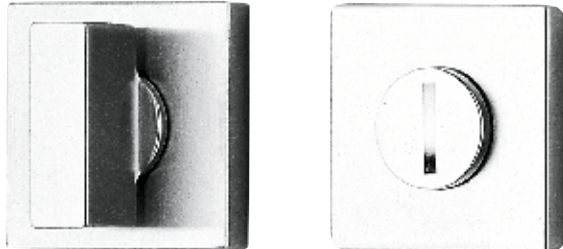

H202V6
H202V6 B



Brass

SGP Super Gold Polished
C Chrome
MC Matt Chrome
BP Biochrome Polished
SNS Super Nickel Satin
SSSS Super Stainless Steel Satin

C Chrome
MC Matt Chrome
SSSS Super Stainless Steel Satin

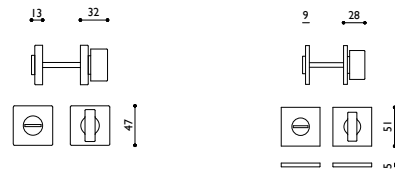

Space Q Studio Olivari

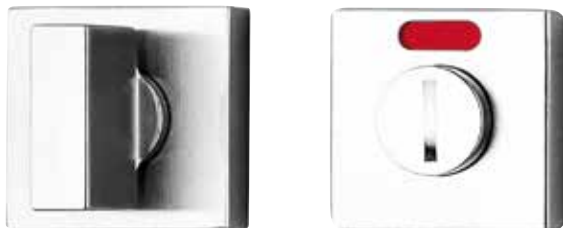

H202VF6



Brass

SGP Super Gold Polished
C Chrome
MC Matt Chrome
BP Biochrome Polished
SNS Super Nickel Satin
SSSS Super Stainless Steel Satin

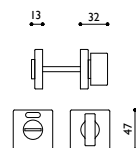

Space S Studio Olivari



H192B6



Brass

P Polished
SGP Super Gold Polished
C Chrome
MC Matt Chrome
BP Biochrome Polished
SNS Super Nickel Satin
SSSS Super Stainless Steel Satin

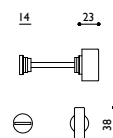

Chiavistelli

Link Piero Lissoni

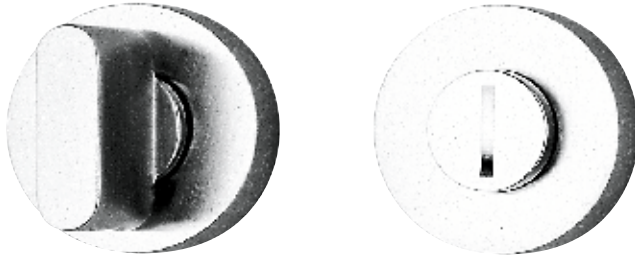

H200V6
H200V6B



Brass

- P Polished
- SGP Super Gold Polished
- C Chrome
- MC Matt Chrome
- BP Biochrome Polished
- BS Biochrome Satin
- SNS Super Nickel Satin
- SSSS Super Stainless Steel Satin

- C Chrome
- MC Matt Chrome
- SSSS Super Stainless Steel Satin

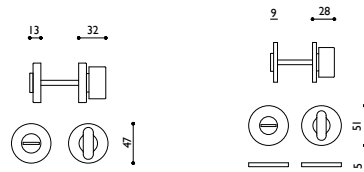

Link Piero Lissoni



H200VF6



Brass

- P Polished
- SGP Super Gold Polished
- C Chrome
- MC Matt Chrome
- BP Biochrome Polished
- BS Biochrome Satin
- SNS Super Nickel Satin
- SSSS Super Stainless Steel Satin

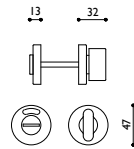

Link S Piero Lissoni



H199B6



Brass

- P Polished
- SGP Super Gold Polished
- C Chrome
- MC Matt Chrome
- BP Biochrome Polished
- BS Biochrome Satin
- SNS Super Nickel Satin
- SSSS Super Stainless Steel Satin

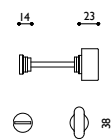

Chiavistelli

Space Studio Olivari

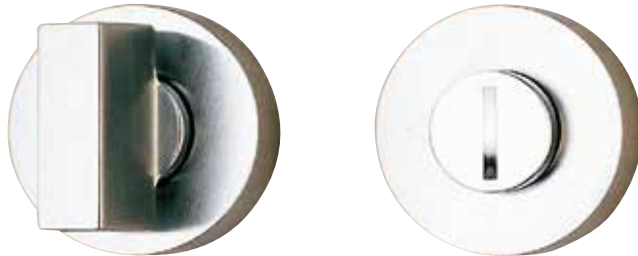

HI93V6



Brass

- P Polished
- SGP Super Gold Polished
- C Chrome
- MC Matt Chrome
- BP Biochrome Polished
- SNS Super Nickel Satin
- SSSS Super Stainless Steel Satin

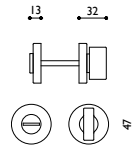

Space Studio Olivari



HI93VF6



Brass

- P Polished
- SGP Super Gold Polished
- C Chrome
- MC Matt Chrome
- BP Biochrome Polished
- SNS Super Nickel Satin
- SSSS Super Stainless Steel Satin

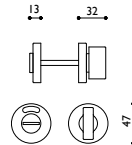

Space S Studio Olivari



HI92B6



Brass

- P Polished
- SGP Super Gold Polished
- C Chrome
- MC Matt Chrome
- BP Biochrome Polished
- SNS Super Nickel Satin
- SSSS Super Stainless Steel Satin

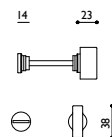

Manigioni

Planet Studio Olivari



Brass

- SGP** Super Gold Polished
- SG** Super Gold Polished/Satin
- C** Chrome
- MC** Matt Chrome
- C/MC** Chrome/Matt Chrome
- SNS** Super Nickel Satin
- SSSS** Super Stainless Steel Satin

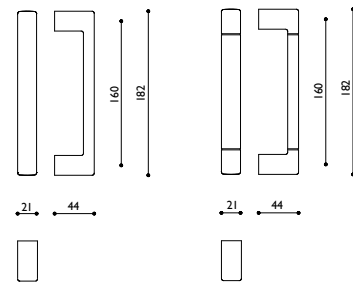

L195

L195

Manigioni

Bios
Studio Olivari



Brass

C Chrome

MC Matt Chrome

SSSS Super Stainless Steel Satin

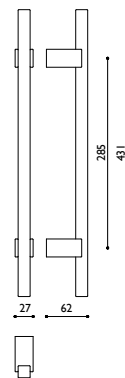
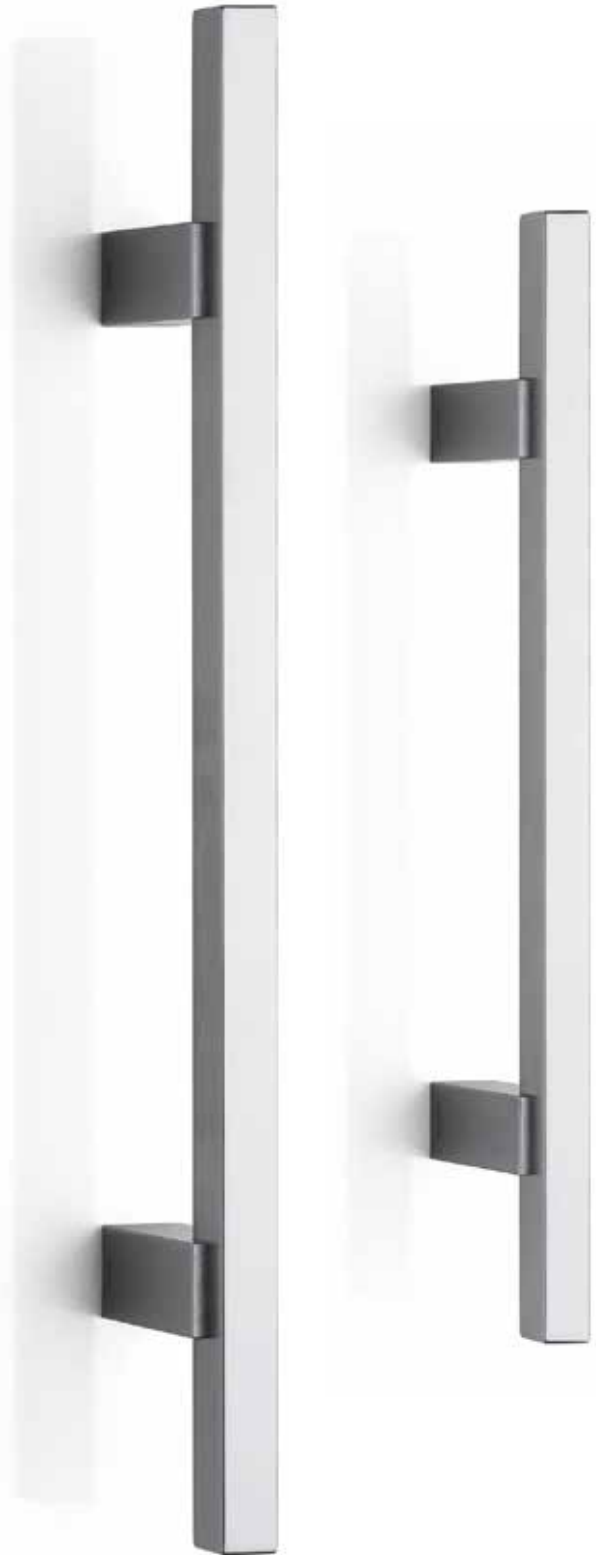

L205

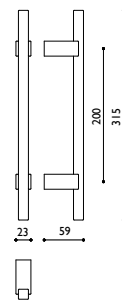

L204

Manigioni

Diana
Studio Olivari

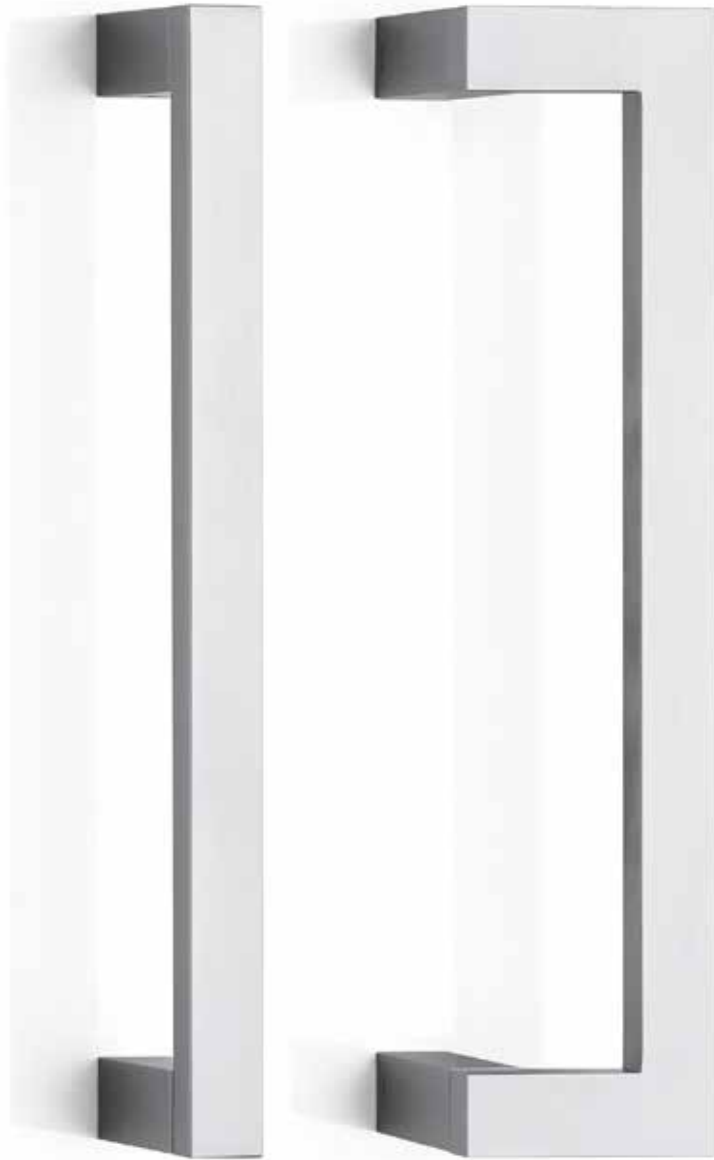

Brass

- C Chrome
- MC Matt Chrome
- BP Biochrome Polished
- SSSS Super Stainless Steel Satin

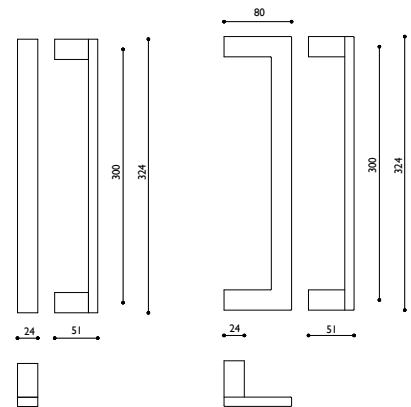

L206

L207

Maniglioni

Link

Piero Lissoni



Brass

- C Chrome
- MC Matt Chrome
- BP Biochrome Polished
- BS Biochrome Satin
- SSSS Super Stainless Steel Satin

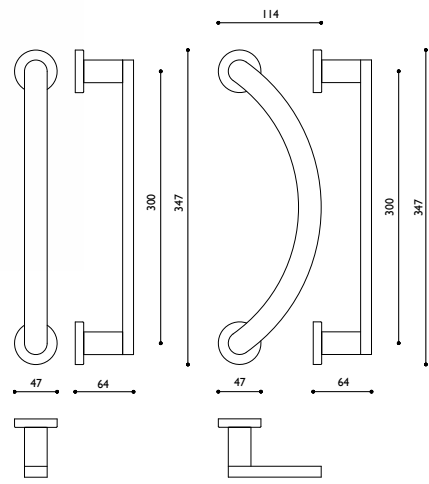

L199R

L200R

Maniglioni

Link
 Piero Lissoni



Brass

- C Chrome
- MC Matt Chrome
- BP Biochrome Polished
- BS Biochrome Satin
- SSSS Super Stainless Steel Satin

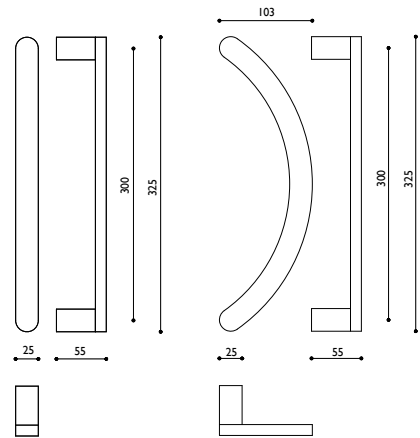
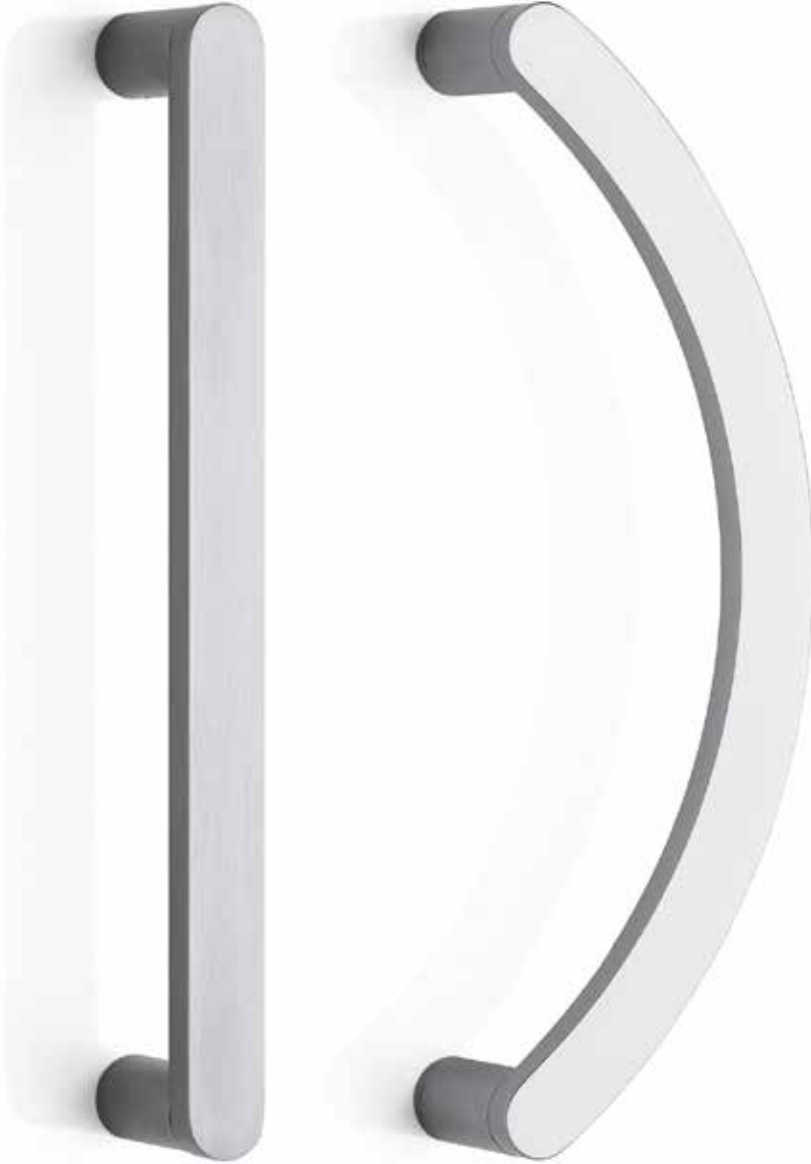

L199

L200

Maniglioni

Stilo
 Enzo Mari



Brass

- SGP Super Gold Polished
- C Chrome
- MC Matt Chrome
- SSSS Super Stainless Steel Satin

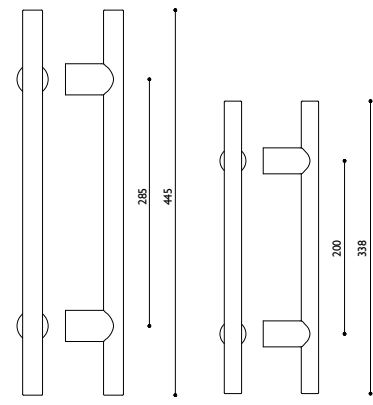

L190L

L190M

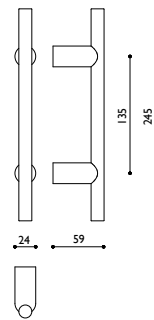

L189

Maniglioni

Aster
Penta Associati



Brass

P/S Polished/Satin
SG Super Gold Polished/Satin
C/MC Chrome/Matt Chrome

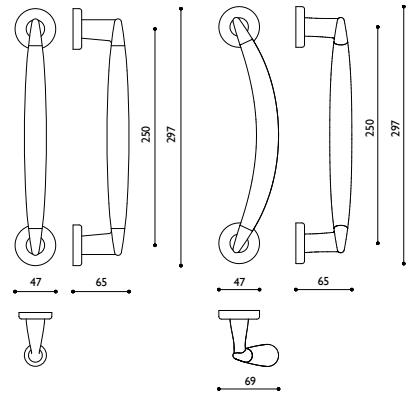

LI74R

LI75R

Maniglioni

Icaro
Paolo Portoghesi



Comet
Nicola Novelletto



Brass
SGP Super Gold Polished

Brass
C/MC Chrome/Matt Chrome

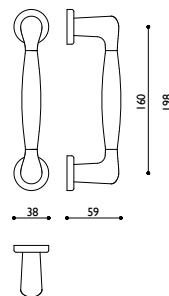
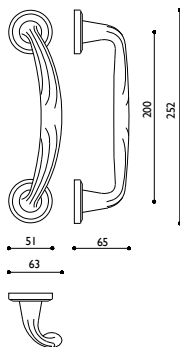

L168A

L183R

Fermaporte

Cubo Studio Olivari

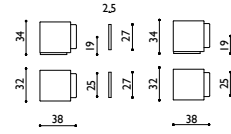

Brass

- C Chrome
- MC Matt Chrome
- BP Biochrome Polished
- SNS Super Nickel Satin
- SSSS Super Stainless Steel Satin

B136C magnetico
B136S non magnetico

Victor Studio Olivari

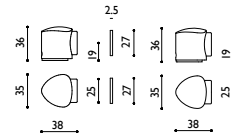

Brass

- P Polished
- SGP Super Gold Polished
- S Satin
- C Chrome
- MC Matt Chrome
- SNS Super Nickel Satin
- SSSS Super Stainless Steel Satin

B106C magnetic
B106S non magnetic

Raffaella Studio Olivari



Brass

- P Polished
- SGP Super Gold Polished
- S Satin
- C Chrome
- MC Matt Chrome
- BP Biochrome Polished
- BS Biochrome Satin
- SNS Super Nickel Satin
- SSSS Super Stainless Steel Satin

B102

Sector Studio Olivari



Brass

- P Polished
- SGP Super Gold Polished
- S Satin
- C Chrome
- MC Matt Chrome
- SNS Super Nickel Satin

B101

Gardena Studio Olivari



Brass

- SGP Super Gold Polished
- S Satin
- AN Antiqued

B103

Siena Studio Olivari



Brass

- P Polished
- AN Antiqued

B104

Stilo Studio Olivari

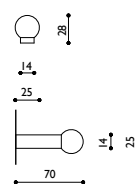

Brass

- P Polished
- SGP Super Gold Polished
- C Chrome
- MC Matt Chrome

B121
B123 wall

Appendiabiti

Bond Andrea Branzi



EI 63A

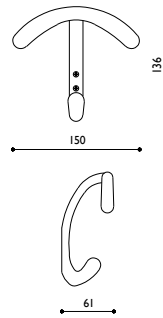

Brass

- P Polished
- C Chrome
- MC Matt Chrome

Alexandra F.A. Porsche



EI 50

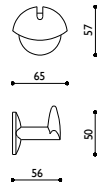

Brass

- C Chrome
- MC Matt Chrome

Polo Rodolfo Bonetto



EI 52

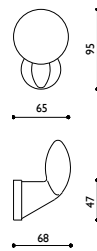

Brass

- SGP Super Gold Polished
- C Chrome
- MC Matt Chrome

NORWICH

61-67 St. Benedicts Street,
Norwich, NR2 4PD
Tel: 01603 216500
Fax: 01603 216510
Email: sales@acleigh.co.uk

COLCHESTER

11 Grange Way,
Whitehall Industrial Estate,
Colchester, CO2 8HG
Tel: 01206 877488
Fax: 01206 877480
Email: colchester@acleigh.co.uk

IPSWICH

Unit 2-3, Dencora Business Centre,
Whitehouse Road, Ipswich, IPI 5LT
Tel: 01473 292810
Fax: 01473 292818
Email: ipswich@acleigh.co.uk

www.acleigh.co.uk