



# AC LEIGH

ARCHITECTURAL IRONMONGERS  
SECURITY SPECIALISTS

## ARCHITECTURAL IRONMONGERY

### OPERATION & MAINTENANCE MANUAL

Colchester

11 Grange Way, Whitehall Industrial Estate,

Colchester, CO2 8HG

Tel: 01206 877488 Fax: 01206 877480

Email: colchester@acleigh.co.uk



**AC LEIGH**

ARCHITECTURAL IRONMONGERS  
SECURITY SPECIALISTS

## CONTENTS

Introduction

1. Lever Assembly

2. Pull Handles

3. Overhead Door Closers

4. Floor springs

5. Door Co-ordinators

6. Lock cases & Cylinders

7. Panic Hardware

8. Hinges

9. Flush bolts

10. Care of Finishes

## Colchester

11 Grange Way, Whitehall Industrial Estate,

Colchester, CO2 8HG

Tel: 01206 877488 Fax: 01206 877480

Email: colchester@acleigh.co.uk



# INTRODUCTION

Care and maintenance are important factors in ensuring that all products supplied by AC Leigh maintain a high quality finish, and that working components operate effectively.

AC Leigh has prepared this operation & maintenance manual to assist the architect, contractor and maintenance personnel with the upkeep of all products supplied to your Contract.

This operation and maintenance manual has been prepared to help you maintain the quality ironmongery that you have fitted to your building. Once fitted and in use, it is essential that regular inspection, cleaning and checks of the fixings are carried out. This will give you many years of satisfaction. The frequency of maintenance will depend on the amount of use individual products receive.

This manual is also divided into product sections and explains the problems that can occur through incorrect fitting, incorrect use, abuse and prolonged use of the various products together with the remedies to the problems.

Where reference is made to aerosol lubricants, we recommend 'WD40' or a PTFE lubricant. Cylinders require a graphite aerosol, available via AC Leigh.

Where reference is made to grease, a lithium or graphite filled grease is recommended.

Please note that this manual is designed as a guide only. If you have any questions relating to the O&M of specific items within your building, please don't hesitate to call our Contracts Team on 01206 877488 who will be happy to provide any additional information you may need.

## Colchester

11 Grange Way, Whitehall Industrial Estate,

Colchester, CO2 8HG

Tel: 01206 877488 Fax: 01206 877480

Email: colchester@acleigh.co.uk



# AC LEIGH

ARCHITECTURAL IRONMONGERS  
SECURITY SPECIALISTS

## I. LEVER ASSEMBLY

### OPERATION

The function of the lever furniture is to facilitate rotation of a lock follower which in turn withdraws the latch bolt of a lock.

The lever furniture is unsprung and designed for use with mortice locks with 8 or 9.5mm followers. The bearings are contained within an assembly designed for high endurance.

The levers are assembled to the inner rose and bearing assembly, bolted back to back via holes in the lock case to the opposite lever and fixed with grub screws to the spindle for ultimate security and functional performance. The single side fixing spindle involves the use of a fixing plate with tapped inserts to copy the effect of the back to back fixing.

The single side fixing spindle when correctly fitted is secured on both sides of the lock follower and then fixed with a cone pointed grub screw to the spindle.

### MAINTENANCE

FAULT: LOOSE LEVERS		
SYMPTOM	POSSIBLE CAUSE	ACTION TO RECTIFY
Handles loose on door	Fixings loose	Tighten fixings under roses (one from each side) with a M2.5 ball ended hexagon wrench and tighten grub Screws in the levers. In persistent cases locktite should be applied to the Fixings before re tightening.
Handles stiff to operate and not returning to horizontal position	Fixings too tight	Remove outer rose covers and slightly loosen fixings.
Handles not returning to rest position	Mortice for lock case not square to face of door	Remove handles and lock case, rectify mortice and re-fit ironmongery.



## 2. PULL HANDLES

### OPERATION

Pull handles are normally fitted to high usage doors or corridor doors, which are unlatched allowing free movement from area to area. Some doors are fitted with a single pull on the hinge side of the door and a push plate on the reverse side. Other doors, usually double action, are fitted with a pair of handles one each side of the door. It is recommended that on high usage, soft faced or glass doors thrust roses should be fitted. These roses spread the load on the surface of the door and give a major increase to the reliability of the smaller diameter (less than Ø25mm) pull handles.

### MAINTENANCE

FAULT: LOOSE PULL HANDLES		
SYMPTOM	POSSIBLE CAUSE	ACTION TO RECTIFY
Single side handle loose on door	Fixings loose Oversize holes	Remove push plate and tighten bolt with posi drive screwdriver. If problem persists apply locktite to bolt before re tightening.  If the handle has damaged the face of the door, consider adding a thrust rose between the door face and the handle.  On steel doors a spacer between the door skins will ensure a solid fixing re-assemble with thrust roses and tubes.
Back to back pull handles loose on door	Fixings loose Oversize holes	Test the pull handle without visible fixings, if this handle is loose remove other handle and tighten the special bolt which fixes through the door into the opposite handle, test the handle again and once it is secure with all play removed re-assemble the other handle and secure with the grub screws provided.  On steel doors a spacer between the door skins will ensure a secure fixing. Re-assemble using thrust washers and tubes.



## 3. OVERHEAD DOOR CLOSERS

### OPERATION

The function of a door closer is to close a door after it has been opened. The door closers have various controls, which change the closing characteristics depending on the ambient conditions and particular door requirements.

All models have the basic controls of closing speed and a control to overcome difficult latches, in addition some models have an adjustable zone backcheck.

Power adjustable closers offer the facility to reduce the power for easy access by the disabled or increase it to prevent doors opening in strong winds. Most power adjustable closers leave the factory with their power setting at 3, the minimum required for a Fire Rated door to ensure that the door closes and overcomes any seals that may be fitted. On these doors the power strength should not be reduced from the factory setting.

Some closers have electromagnetic functions which automatically close a door in the event of the fire alarms being raised. These door closers are also protected by overload abuse safety valves against accidental or deliberate misuse.

**Warning: Door controls contain a powerful spring, which is inserted into the body under pressure and should not be removed except by the manufacturer.**

### MAINTENANCE

The internal mechanisms are completely immersed in oil and they are designed so that no internal maintenance is required. Once the door control has been correctly fitted to suit local conditions, no further adjustments should be necessary. However, a frequent check should ensure that the door closes freely and positively into the frame, without slamming and that all of the fixing screws are tight.

FAULT: CLOSER MALFUNCTION Adjustments are carried out with end caps removed		
SYMPTOM	POSSIBLE CAUSE	ACTION TO RECTIFY
Door closing too fast	Closing speed incorrectly set	Turn inner control clockwise with adjuster key to attain desired speed.
Door closing too slowly Door not latching	Closing speed incorrectly set	Turn inner control anti-clockwise with adjuster key to attain desired speed.
Latching action not operating		Turn outer control clockwise/anti-clockwise with tool supplied, towards the crescent on the decal. Maximum latch is when the dot on the control is adjacent to the crescent.
Door slamming	Door closing too fast Latching action operable	See Above. Turn outer control clockwise/anti-clockwise with adjuster key so that the dot is opposite crescent.

## Colchester

11 Grange Way, Whitehall Industrial Estate,  
Colchester, CO2 8HG  
Tel: 01206 877488 Fax: 01206 877480  
Email: colchester@acleigh.co.uk



**AC LEIGH**  
ARCHITECTURAL IRONMONGERS  
SECURITY SPECIALISTS

SYMPTOM	POSSIBLE CAUSE	ACTION TO RECTIFY
Door holding open	Speed set on minimum Door binding on hinges	Adjust inner control. Disconnect closer arm and make sure door closes freely into jamb.
Door difficult to open	Power setting too high (Do not adjust for fire doors)	Turn power control anticlockwise with adjuster key or large screwdriver until door closes with minimum effort.
Door blows open in wind	Power setting too low for ambient conditions	Turn power control clockwise until a satisfactory condition is reached.
Door opens so far and then Meets resistance, or, door fully opens and hits wall.	Back check setting	Adjust power control clockwise (maximum to minimum angle within half turn) to attain desired angle of back check. Maximum is when the dot is adjacent to the crescent.

## DELAYED CLOSING MODELS

### OPERATION

The delayed closing function is adjustable for both duration and angle of operation. The closers always have the normal controls appropriate to the model. The adjustable delayed function slows down the initial closing phase of the door in order to ease the progress of trolleys, heavy pedestrian traffic and users of wheel chairs. The delayed closing gives an extra 20 seconds of holding time in addition to the normally selected closing speed of the door. The delay can be manually overcome at any time by pulling the door towards the closed position.

## HOLD OPEN FUNCTION MODELS

### OPERATION

To hold open a door until the door is pulled from the retained position. Once the door is manually pulled from the held position the door will close normally under the set controls. The door must be pushed open to greater than 90° for the door to be held open at 90°. The closer has all of the normal controls appropriate to the model.

It is important that this type of closer is never used on a fire door.

### FAULT: HOLD OPEN CLOSER MALFUNCTION

SYMPTOM	POSSIBLE CAUSE	ACTION TO RECTIFY
Door not closing	Fig 1 Bracket arm not square to face of door	Adjust length of arm to achieve 90°.
Door not holding at 90°	Closer bracket not in correct position	Re-fit bracket to template supplied with closer.

## Colchester

11 Grange Way, Whitehall Industrial Estate,

Colchester, CO2 8HG

Tel: 01206 877488 Fax: 01206 877480

Email: colchester@acleigh.co.uk



# AC LEIGH

ARCHITECTURAL IRONMONGERS  
SECURITY SPECIALISTS

## CONCEALED OVERHEAD DOOR CLOSER 9124

### OPERATION

The concealed model is mounted within the top of the door. The door closer has controls for speed of closing and a latch function to overcome difficult latches and seals. The power of the spring can be adjusted, it can be reduced to allow easy access for the disabled or the power can be increased to prevent the door from opening in the event of strong winds.

### MAINTENANCE

The closer is a sealed unit and no maintenance is possible except for checking that all of the fixing screws are secure. There are adjustments that can be made which may be required when the function of the building changes or conditions change. All of the adjustments are carried out with the door open. The adjustments for speed, latch action and power are all visible when viewed from the top of the door the opening angle of the door is adjusted by moving the stop within the aluminium channel.

FAULT: CONCEALED CLOSER MALFUNCTION		
SYMPTOM	POSSIBLE CAUSE	ACTION TO RECTIFY
Door closing too slowly	Unsuitable speed setting	Turn speed adjustment screw anti-clockwise using 3mm hexagon wrench.
Door closing speed too fast	Unsuitable speed setting	Turn speed adjustment screw clockwise using 3mm hexagon wrench.
Latching speed too fast	Unsuitable latch setting	Turn latch adjustment screw clockwise using 3mm hexagon wrench.
Latching speed too slow	Unsuitable latch setting	Turn latch adjustment screw anti-clockwise using 3mm hexagon wrench.
Door difficult to open	Power setting too high	Turn power adjustment screw clockwise using 5mm hexagon drive in ratchet driver.
Door blows open in wind	Power setting too low	Turn power adjustment screw anti-clockwise using 5mm hexagon drive in ratchet driver.
Door opening up & hitting wall or frame	Cushion stop needs adjustment	Loosen stop screw, adjust stop, and re-tighten screw. Moving the stop closer to the hinge will increase the opening angle.



## Colchester

11 Grange Way, Whitehall Industrial Estate,

Colchester, CO2 8HG

Tel: 01206 877488 Fax: 01206 877480

Email: colchester@acleigh.co.uk



# AC LEIGH

ARCHITECTURAL IRONMONGERS  
SECURITY SPECIALISTS

## TRANSOM CLOSER

### OPERATION

The transom closer is situated in the headframe above the door. It both closes the door and provides the hinge system. It has two adjustments, one control to adjust the closing speed and the second one speeds up the closing of the door at the end of the sweep to overcome difficult latches.

### MAINTENANCE

There are two adjusting screws on the transom closer; they are visible through the holes in the cover plate on the transom. The adjustment screw nearest to the hinge side is for the closing speed. The other screw adjusts the closing speed of the door over the last 20° of the sweep of the door.

#### FAULT: TRANSOM CLOSER MALFUNCTION

SYMPTOM	POSSIBLE CAUSE	ACTION TO RECTIFY
Leading edge of door drags on floor	Loose fixings on retaining block Pivot not fixed or correctly located	Remove clip at hinge side head of door; open door to 90°, lock closing speed valve and tighten the cap head screws into the retaining block. Re-align and re-fix.
Door closing too slowly	Unsuitable speed setting	Turn screw nearest to hinge anti-clockwise.
Door closing speed too fast	Unsuitable speed setting	Turn screw nearest to hinge clockwise.
Latching speed too fast	Unsuitable latch setting	Turn the other adjusting screw anti-clockwise.
Latching speed too slow	Unsuitable latch setting	Turn the other screw clockwise.

## Colchester

11 Grange Way, Whitehall Industrial Estate,

Colchester, CO2 8HG

Tel: 01206 877488 Fax: 01206 877480

Email: colchester@acleigh.co.uk



# AC LEIGH

ARCHITECTURAL IRONMONGERS  
SECURITY SPECIALISTS

## ELECTRO MAGNETIC OVERHEAD CLOSERS

### OPERATION

When the door is opened a spring within the body of the door closer is compressed and oil pressure is held back by an electro magnet solenoid. When the power to the solenoid is cut off then the solenoid releases the valve and the door will close under the controlled flow of oil within the body of the closer. The door closer is 'fail safe' and will always close the door in the event of any interruption to the power supply. The closer will continue to work as a normal door closer until the power supply is restored. Electro magnetic devices, for reasons of safety, are designed so that the door cannot be held open at less than 70°.

### MAINTENANCE

It is recommended that the **weekly check** of the fire alarm system should determine the need for adjustment of any component of the doorset. Any failure of the door to close completely into the seals should be investigated and corrected.

#### FAULT: ELECTRO MAGNETIC CLOSER MALFUNCTION

SYMPTOM	POSSIBLE CAUSE	ACTION TO RECTIFY
Door closing too fast	Closing speed incorrectly set	Turn inner control clockwise with adjuster key to attain desired speed.
Door closing too slowly	Closing speed incorrectly set	Turn inner control anticlockwise with adjuster key to attain desired speed.
Door not Latching	Latching action not operative	Turn outer control clockwise/anti-clockwise with tool supplied, towards the crescent on the decal. Maximum latch is when the dot on the control is adjacent to the crescent.
Door slamming	Door closing too fast	See above.
Door not holding open	Switch set in wrong position	Set switch to HOLD and not delayed close.
Door holding open	Permanent hold set	Set switch to DELAYED CLOSE and select closing time. Check that the voltage is between 21 –28V.
Door holding open	Trip cap incorrectly set	Set trip cap to correct angle.



## 4. FLOOR SPRINGS AND ELECTRO MAGNETIC FLOOR SPRINGS

### OPERATION

When the door is opened a spring within the body of the floor spring is compressed and oil pressure is held back by an electro magnet solenoid. When the power to the solenoid is cut off then the solenoid releases the valve and the door will close under the controlled flow of oil within the body of the spring. The floor spring is 'fail safe' and will always close the door in the event of any interruption to the power supply. The floor spring will continue to work as a normal floor spring until the power supply is restored. Electro magnetic devices, for reasons of safety, are designed so that the door cannot be held open at less than 65°. The floor springs have various controls which change the closing characteristics of the door. The controls include speed of closing, power of backcheck and some models have power adjustment. The floor springs are typical of universal double action floor springs. They will not close a door if it is fully opened to 180°.

It is essential that all doors close, especially fire doors. If the frame detail allows a door to open beyond 170° then a doorstop must be positioned to restrict the opening angle to 170°.

### MAINTENANCE

Once the floor spring has been installed it should be checked annually to ensure that the door closes fully into the frame without slamming. Additionally on the electro magnetic it is recommended that a **weekly check** of the fire alarm system should determine the need for adjustment of any component of the doorset. Any failure of the door to close completely into the seals should be investigated and rectified.

#### FAULT: FLOOR SPRING MALFUNCTION

SYMPTOM	POSSIBLE CAUSE	ACTION TO RECTIFY
Door closing too fast	Closing speed incorrectly set	Turn speed control 'K' with spanner clockwise until desired closing speed is attained.
Door closing too slowly	Closing speed incorrectly set	Turn speed control 'K' with spanner anti-clockwise until desired closing speed is attained.
Door slamming	Closing speed incorrectly set	See above.
Door not holding open	Contact with floor covering, etc. Hold open model fitted?	Make sure door is hung correctly. Check floor spring type.
Door not opening/closing correctly 'creaking' can be heard	Binding on pivots	Make sure door is hung correctly.
Door misaligned	Door / frame movement	Turn geared wheel on side of floor spring body
Door not holding open	Electrical failure	Check power supply

**Colchester**

11 Grange Way, Whitehall Industrial Estate,  
Colchester, CO2 8HG  
Tel: 01206 877488 Fax: 01206 877480  
Email: colchester@acleigh.co.uk

SYMPTOM	POSSIBLE CAUSE	ACTION TO RECTIFY
Erratic closing speed		Re-commission spring. With power off. Adjust closing speed to 3-4 secs. Open door 20 times & check if closing speed is consistent. <b>CONNECT POWER</b> Open door to required angle >80° (it may fall back 3°) this is normal. Check that the door closes when power interrupted. Check if closing speed is greater than 7 seconds – if so repeat this commissioning procedure.
Door too difficult to open	Power setting incorrect	Turn power control 'L' anticlockwise with until the minimum power is achieved to close the door.

Please see diagram below. Please note not all features are included on all models.

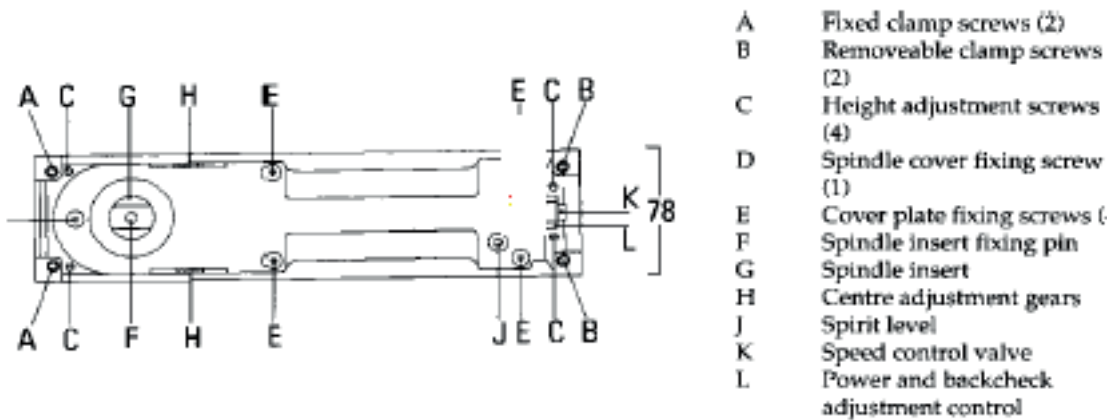



## 5. DOOR CO-ORDINATOR

### OPERATION

Unless rebated double fire doors close fully, rebate to rebate, then they do not give the full fire protection to the building and its occupants. The function of a door co-ordinator is to ensure that rebated doors always close in the correct order.

### MAINTENANCE

The door co-ordinator is an essential piece of fire hardware and it should be checked weekly. The only routine maintenance is to check the security of all fixing screws & tighten where necessary.

The method of checking the function is shown in figure 5.1 below :-

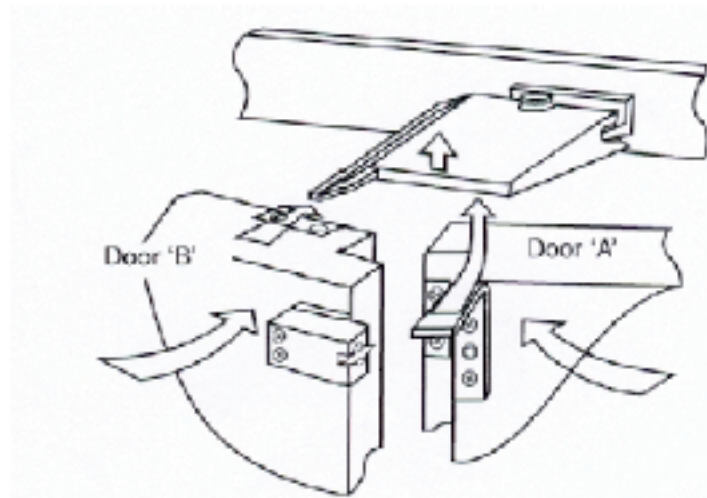

Figure 5.1

The door co-ordinator operates by ensuring that after both doors have been opened door 'A' always closes before door 'B'. When the door closers attempt to close door 'B' first, the arm holds door 'B' open until the lift arm on moving door 'A' raises the body off the impact plate and door 'B' continues to close following door 'A'



## 6. LOCK CASES AND CYLINDERS

### OPERATION

The function of a lock is to secure a door within its frame and allow access and egress to authorised holders of the key. There are many different types of lock all with their own individual functions. Before any maintenance is carried out it is important to know the lock function.

The mechanical components vary between lock types, and some are so complex that they are only suitable for repair by skilled locksmiths. It is important that lock cases are not opened as incorrect assembly could lead to building occupants being locked inside or outside of buildings.

### MAINTENANCE

Check that all fixings are fully tightened, and that the latchbolt enters the strike smoothly - adjust if required. At regular intervals, apply aerosol lubricant into the case around the latch/deadbolt. We recommend 'WD40' or a PTFE lubricant.

FAULT: LOCK MALFUNCTION		
SYMPTOM	POSSIBLE CAUSE	ACTION TO RECTIFY
Latch bolt not returning into lock case when door closes	Lack of lubrication Strike plate moved	Apply lubrication oil to the latch bolt. Thin machine oil or aerosol can be used. Check position and angle of strike plate and tighten fixing screws.
Latch bolt staying in lock case	Mortice too tight	Remove lock & rectify mortice.
Levers not returning to horizontal	Lever return spring broken	Replace springs or replace lock. (See note below)
Door slams & bounces off strike plate	Mortice too wide, strike plate is loose or door post unstable	Pack lock case to fit mortice. Secure strike plate more firmly.
Bolt not engaging into strike plate (check lock with door open to see if bolt throws)	Strike incorrectly adjusted Door dropped	Adjust strike. Check hinge fixings and adjust.

Note: Whenever evidence of lockcases being opened or that the inner components have been tampered with, the guarantee will be considered void.

## Colchester

11 Grange Way, Whitehall Industrial Estate,

Colchester, CO2 8HG

Tel: 01206 877488 Fax: 01206 877480

Email: colchester@acleigh.co.uk



# AC LEIGH

ARCHITECTURAL IRONMONGERS  
SECURITY SPECIALISTS

## CYLINDERS

### OPERATION

The purpose of a cylinder is to operate the component of a lock to allow keyholders only to access the elected area of a building. There are small components within the cylinder. Door seals, warping and the normal shrinkage and contraction of doors in varying weather conditions affect the forces required to close the door. Keys are not designed to be used as cylinder pulls and they **will break**. A cylinder pull should be for this function.

### MAINTENANCE

It is recommended that only a proprietary graphite aerosol lubricant is used in and around the cylinder; key and turn in order to maintain efficient working of the cylinder. **Do not use oil, grease or any other lubricant as this may cause the small intricate internal components within the cylinder to stick together and malfunction.**

#### FAULT: CYLINDER DIFFICULT TO OPERATE

SYMPTOM	POSSIBLE CAUSE	ACTION TO RECTIFY
Cylinder stiff to operate	Lubrication dried out	Lubricate with graphite aerosol.
	Cylinder not central within lock	Slacken cylinder retaining screw, centre cylinder and re-tighten screw.
	Lock not square to face of door	Remove lock and rectify mortice.
Cylinder not operating	Worn pins or key	Replace.

## Colchester

11 Grange Way, Whitehall Industrial Estate,  
Colchester, CO2 8HG  
Tel: 01206 877488 Fax: 01206 877480  
Email: colchester@acleigh.co.uk

# 7. PANIC HARDWARE

## OPERATION

The operation of panic hardware is to allow fast egress from a building in the event of a fire or other emergency situation. Panic hardware is designed as a 'life saver' there should be no doubt as to its performance on any door.

All panic hardware used within the EU should carry a mandatory CE mark, which will be required from April 2003. These products should be fitted in accordance with the instructions supplied and not be modified in any way other than in accordance with the instructions as this could affect product function and will invalidate any guarantee.

The European Standard for these devices, BS EN 1125 contains the following recommendation for maintenance and testing. "It is recommended that the following routine maintenance checks should be undertaken at intervals of not more than one month by the occupier or his approved representative. Check all fixings and inspect and operate the panic device to ensure that all components are in a satisfactory working condition. Ensure that the keeper(s) is (are) free from obstruction." The results of these inspections should be recorded.

## MAINTENANCE

Remove the end cap and the end cover opposite to the hinge side, you will see the cruciform plate. Apply a light grease to the four points where the plate rubs near to the bushes.

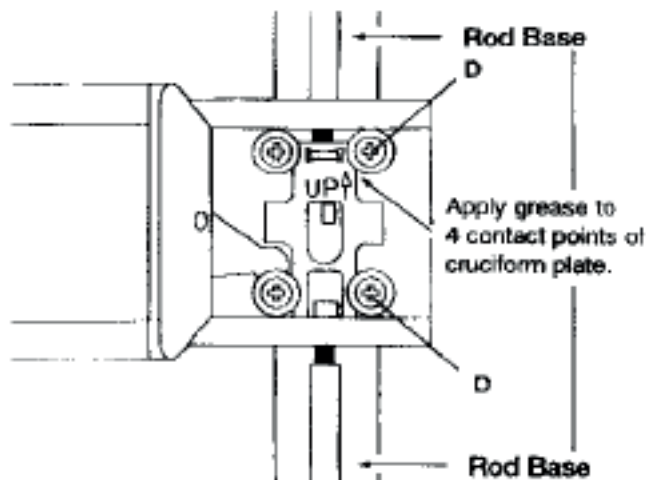





## 8. HINGES

### OPERATION

The function of the hinges is to provide a free and safe movement of the door from the closed to the open position. All hinges are independently tested - some carry doors up to 160kg in weight based on doors of 970mm wide. High usage doors may require the higher performance hinges. Some butt hinges are lubricated for life and any further lubrication could reduce the life of the bearings **please check with AC Leigh which hinges are installed into your building prior to undertaking any lubrication.** Rising and falling hinges suffer from a point loading on the cams, regular lubrication of the cams with a good quality grease is essential. All hinges are supplied with fixings. Any substitution of the fixings supplied may reduce the load carrying performance. Hinges should be fitted exactly vertical. Where mortices are not machined accurately then hinge bind may occur. Hinge binding results in the door being difficult to open & close, sometimes this may cause the hinge to squeak. To check that the hinge is acceptable remove it from the door & frame and open & close the flaps, if the hinge does not squeak or is not tight then the door and frame mortices should be examined.

### MAINTENANCE

FAULT: HINGE NOT FUNCTIONING CORRECTLY		
SYMPTOM	POSSIBLE CAUSE	ACTION TO RECTIFY
Leading edge of door drags on floor	Loose fixings Hinges not in line	Tighten screws. Remove door and check alignment.
Hinge squeaking	High frequency use over a long period Hinge knuckles rubbing on frame Hinge bind	Lubricate bearings with WD40 or Triflow. Re-position hinges to miss frame. Remove hinge from door & frame check that the hinge is not tight to operate and that it does not squeak.
Rising & falling hinges tight	Lack of lubrication Cams 'swelling' due to lack of lubrication	Lubricate with good quality grease. Lubricate & check function. If tight replace hinges.

## Colchester

11 Grange Way, Whitehall Industrial Estate,

Colchester, CO2 8HG

Tel: 01206 877488 Fax: 01206 877480

Email: colchester@acleigh.co.uk



# AC LEIGH

ARCHITECTURAL IRONMONGERS  
SECURITY SPECIALISTS

## 9. FLUSH BOLTS

### OPERATION

Lever action flush bolts are used to lock or bolt a door (usually one of a pair of double doors). As the name suggests they can be fitted flush with the face of a door or on the edge of the door where they are then fully concealed when the doors are closed. The bolts can be fitted at the top or bottom of the door; the bottom ones should be provided with easy clean sockets for fixing into the floor.

### MAINTENANCE

FAULT: STIFF/DIFFICULT TO OPERATE		
SYMPTOM	POSSIBLE CAUSE	ACTION TO RECTIFY
Stiff / difficult to operate	Lubrication dried up Not properly morticed  Easy clean socket full of debris	Apply WD40 to base of operating lever. Remove bolt & remortice to clear the full depth of the bolt.  Clean sockets regularly.

## Colchester

11 Grange Way, Whitehall Industrial Estate,

Colchester, CO2 8HG

Tel: 01206 877488 Fax: 01206 877480

Email: colchester@acleigh.co.uk



# AC LEIGH

ARCHITECTURAL IRONMONGERS  
SECURITY SPECIALISTS

## 10. CARE OF FINISHES

Preventing corrosion and deterioration is easier than trying to restore a product after it has deteriorated. To avoid the risk of damage, decorative and other exposed items of hardware should not be fitted until immediately before handover of the area and after the work of other trades in the area is complete.

Hardware should not be fitted to any surface before the decoration of the surface is complete. **If traces of paint or other 'wet' processes are found on the products then any guarantee on the finish will be considered void.**

If subsequent redecoration or touching up is required, the hardware should be removed from the surface and refitted after the finish is fully dry. In no circumstances should masking tape or the like be applied to hardware surfaces, as removing the adhesives left by such tape may damage the finish of the protective coatings.

### SATIN ANODISED ALUMINIUM

Wipe clean with a solution of washing-up liquid using a soft cloth or sponge.

### POLISHED BRASS, REGAL BRONZE, SATIN CHROME AND POLISHED CHROME

Wipe clean with a solution of washing-up liquid using a soft cloth or sponge. Do not use any form of metal polish or abrasive as this will destroy the protective coating.

### SATIN STAINLESS STEEL AND PLATINIC STAINLESS STEEL

Wipe clean with a medium strength detergent or white spirit using a soft cloth or sponge. In the event of dirt having accumulated through neglect, application of aerosol lubricant prior to standard cleaning is recommended. A harsh brush should never be used. Stainless steel is the most popular material for swimming pool areas, especially type 316, however the material will stain and suffer from pitting corrosion unless routine washing with clean fresh water is carried out regularly. The brown stains that may appear are evidence of superficial pitting corrosion and is caused by a build up of corrosive salts which is the direct result of higher pool temperatures and humidity and the lack of routine washing with fresh clean water.

### COLOURED POWDER COATED AND BIOCOTE®

Wipe clean with a solution of washing-up liquid using a soft cloth or sponge, rinse and dry with a dry soft cloth. Do not use solvent based or abrasive cleaning materials.

Note: The proprietary products mentioned above are given only as a guide for the quality to be used.