

DIMENSIONS

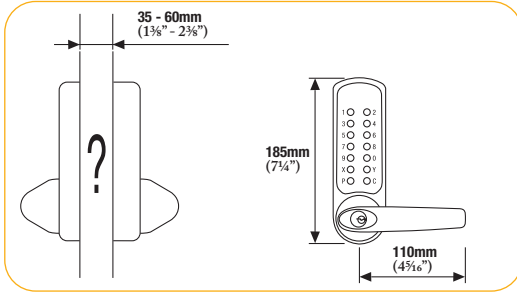

Model 600/605
For use with existing lock

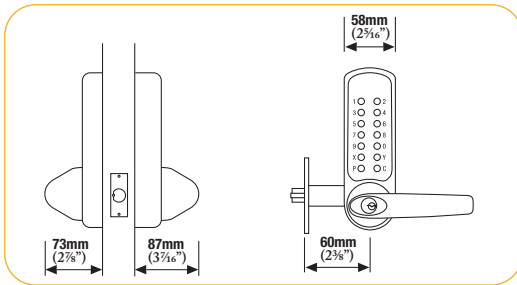

Model 610/615
With tubular latchbolt

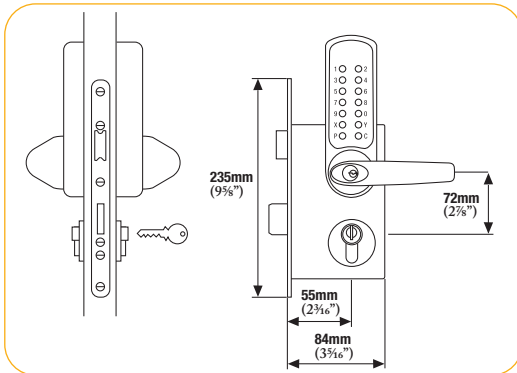

Model 620/625
With full 'Panic Function'
mortice lock & cylinder

FEATURES

- On door code change in seconds.
- Code free entry mode (models 605, 615, 625 only).
- Inside handle always retracts the latch for exit.
- Weather resistant.
- Tamper resistant, with stainless steel buttons, and clutch protection if the outside handle is forced.
- Reversible handles.
- Easy code change as often as required.
- Fits doors between 35mm (1³/₈"

FEATURES - MODEL 620/625 ONLY

- Split follower lock enables inside handle to retract latch and deadbolt simultaneously, satisfying 'means of escape' requirements for exit at all times. Prevents accidental lock-ins.
- Deadbolt thrown by key to lock out code users after work hours.
- Key will retract the latchbolt giving access for admin functions.
- Double Euro-profile cylinder with 3 keys. Any Euro-profile cylinder may be used.
- On multiple door installations consideration should be given to having all cylinders keyed alike, with restricted key issue, for ease of management.

MAINTENANCE

No maintenance of the working parts is necessary. **DO NOT OIL.** To maintain the finish the lock should be cleaned regularly with a soft cloth. A silicone spray or similar should be used to provide a protective film against grit and grime.

CODELOCKS = CONTROL + CONVENIENCE

With a comprehensive range of mechanical and electronic locks, Codelocks provide access control solutions for a wide range of commercial and domestic door applications.

Codelocks Product Range

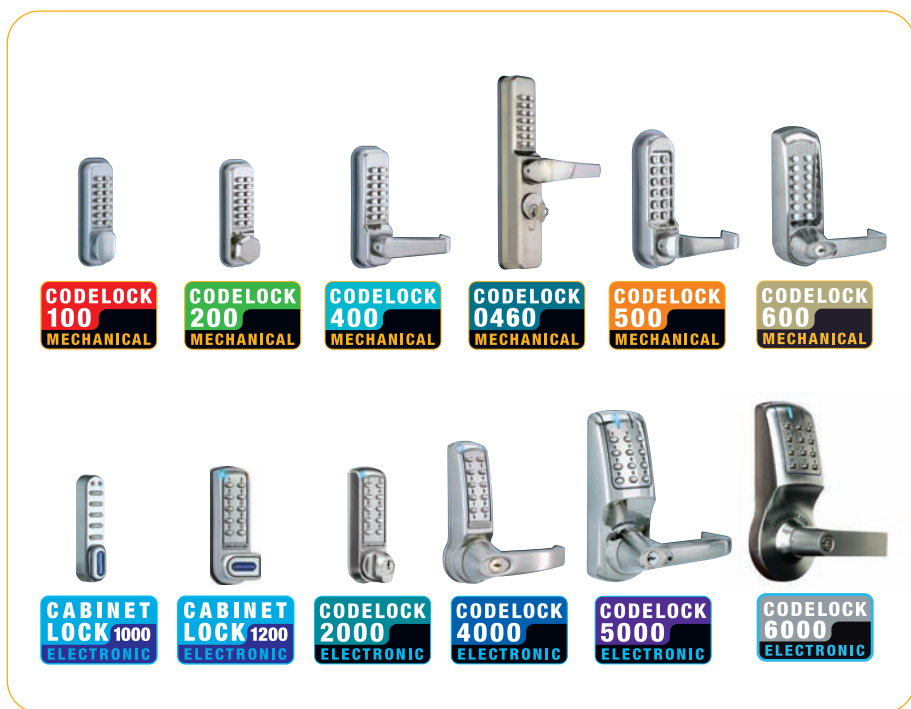

CODELOCKS LTD UK

Tel: +44 (0) 1635 239645

Fax: +44 (0) 1635 239644

sales@codelocks.co.uk

Helpline, service & spares

FREEPHONE 0800 393 405

www.codelocks.com

CODELOCKS US

Tel: 001 714 979 2900

Fax: 001 714 979 2902

sales@codelocks.us

Help: 1.877.CODELOCK



CODELOCKS

control + convenience

**CODE
CHANGE
GUIDE**



**CODELOCK
600
MECHANICAL**



ANSI/BHMA - A156.2

MANY CODES TO CHOOSE FROM

The CL600 range has been designed so the **code can be changed on the door in seconds**. The code chamber (models 600, 610 and 620) consists of 13 buttons and a 'C' button which is used to re-set the code chamber after an incorrect entry, and must always be used as the first digit of a code. Buttons may only be used **ONCE** in a code. For example 1212 is **NOT** possible.

The CL600 ranges code or combination, can be entered in any order or sequence; eg 1234 can be 4321 or 1342 or whatever sequence is most convenient to remember.

With 13 buttons, a total of 8,191 **different** codes are available, any of which can be entered in any sequence.

The total is arrived at as follows:

'C' plus 1 digit = 13
"2" = 78
"3" = 286
"4" = 715
"5" = 1287

'C' plus 6 digit = 1716
"7" = 1716
"8" = 1287
"9" = 715
"10" = 286

'C' plus 11 digit = 78
"12" = 13
"13" = 1
Total = 8191

NOTE: Models 605, 615 and 625 have 12 coded buttons giving 4,095 different codes.

Most people will set the code in the range of 4 to 7 digits, and the total number of codes in this range is 5,434.

The lock is supplied with a random factory set code (see code change card). At any time this can be quickly changed to a new code of your choice.

Typically codes are 4 to 7 digits long. Shorter codes are possible (1-2 digits) but are not recommended.

Passage Free Mode Models 605, 615 and 625

The above feature can be identified with a black dot on the 'P' button.

To set the lock in passage free mode enter the code followed by the 'P' button. The lock will now be in free passage mode.

To put the lock back into code access only press the passage set 'P' button once followed by the C button.

Access under control – the simple and easy way.



CODE CHANGE INSTRUCTIONS

The CL600 range offers significant advantages over other similar mechanical digital locks by allowing the code to be changed in seconds on the door.

Note: Models 605, 615, 625 only – Before changing code press the 'P' and 'C' button to ensure that the lock is not in free passage mode.

1. Choose code.
2. Insert key and turn anticlockwise to stop for right hand hung doors, or clockwise to stop for left hand hung doors. Fig 1.
3. Push the code change tool onto each button in turn, pushing in the buttons approx 2mm ($\frac{3}{32}$ ") **turn anticlockwise 180°**. All buttons should now be in the **non code** position.
4. Test that all buttons are in **non code** position by depressing the lever handle which should retract the latch. If latch cannot be retracted press 'C' button and repeat step 3.
5. To select a button as a **code button**, push code tool over button. Press in button with tool approx 2mm ($\frac{3}{32}$ ") and turn **clockwise 180°**. Fig 2.
6. Now turn the key clockwise for right hand hung doors, or anticlockwise for left hand hung doors **retracting the latch** which will relock the code buttons. Fig 3.
7. Return the key to centre and remove.
8. Before closing door test code.

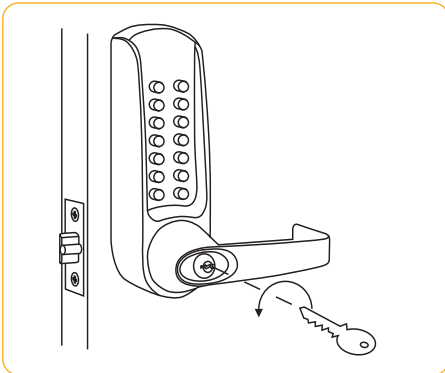

Fig 1 (Image shows right hand hung door)

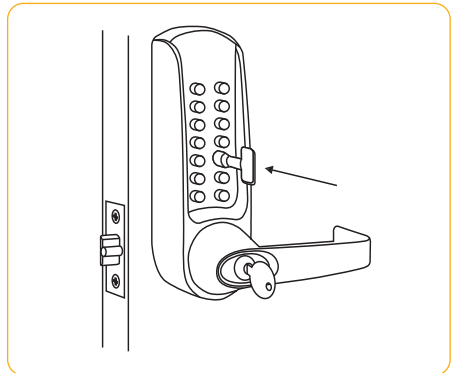

Fig 2

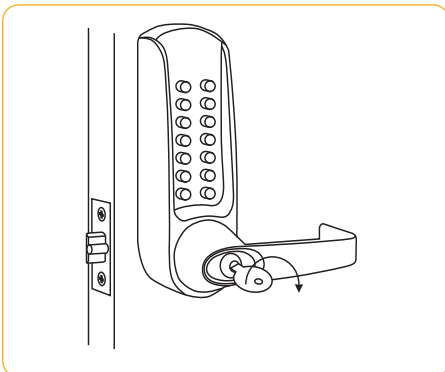
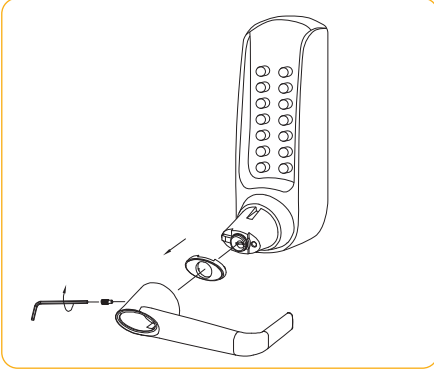

Fig 3 (Image shows right hand hung door)

Removal of front load cylinders to repin or replace with cylinders by a different manufacturer.

1. Remove handle and cylinder cover.



2. Turn Key 90° anticlockwise and remove the cylinder from boss.

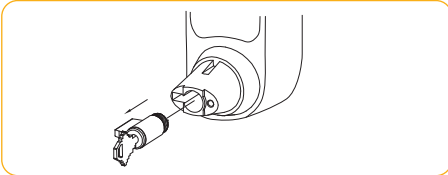

3. To replace cylinder, reinsert and turn 90° clockwise. Replace the cylinder cover and handle.

* If intending to use a cylinder from a different manufacturer it is advisable to confirm beforehand that the new cylinder will fit the boss.

Note that the CL600 uses a 6 pin screw cap cylinder.

If using a screw cap cylinder other than supplied, the tail piece from the Codelocks screw cap cylinder will need to be fitted as follows:

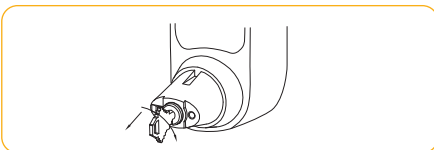

4. Hold down the control pin in the end of the cylinder and unscrew the cap.

CAUTION! DO NOT INSERT THE KEY IN THE CYLINDER ONCE YOU HAVE REMOVED THE SCREW CAP.

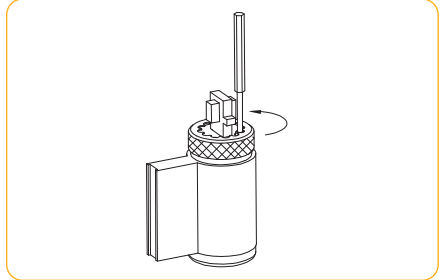

5. Refit the tailpiece, hold down the control pin and screw the cap on fully without tightening. Ensure the control pin projects to lock the cap.

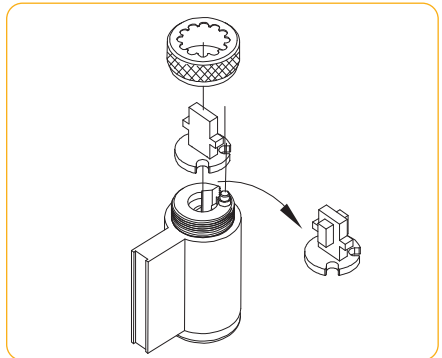

Test the key operation

If the key is difficult to insert, or tight when turning, then the cap maybe too tight. Loosen the cap one notch at a time and try the key again. If the key inserts and turns OK, but is difficult to remove, then the cap may be too loose.

Tighten up the cap one notch at a time. Adjust the cap until the key inserts, turns and removes easily.