

POSTBOXES



AC LEIGH

ARCHITECTURAL IRONMONGERS
SECURITY SPECIALISTS

DAD009 SECURED BY DESIGN LETTERBOX4

DAD GATE 5

DAD PARCEL BOX6

DAD ANTI-ARSON RANGE7

DAD SALTO RANGE - RFID PROXIMITY 8

DAD HEAVY DUTY RANGE9

DAD 2010 RANGE10

DAD 2020 RANGE12

DAD 2030 RANGE14

DAD 2035 RANGE15

DAD 2040 RANGE16

DAD 2700 RANGE17

DAD TELESCOPIC SLOPING RANGE18



DAD009 SECURED BY DESIGN LETTERBOX

The DAD009 is the UK's first Secured By Design Letterbox. Made from electro-galvanised steel and available in any powder coated RAL colour. This model is designed to be surface mounted, recessed or freestanding. The patented locking mechanism is activated using a DAD 6 pin security rim lock conforming to EN 1303:2005 Grade 4. This letterbox is the first in the UK to achieve Secured By Design certification, after achieving Grade 2 certification from the new TS 009:2012 standard. The attack and manipulation tests were carried out by Exova Warringtonfire.



SPECIFICATIONS

- 1.5mm thick electro-galvanized steel
- 10 Year guarantee
- Security 6 pin rim lock complete with 3 keys
- 30,000 differs
- Anti drill, anti bump and anti pick lock
- Patented anti fishing device
- Patented hinge protector
- Patented locking mechanism
- Dimensions: 325mm W x 380mm H x 330mm D

OPTIONS

- Permanent engraving
- Integration with a Master Key System
- Available as an individual letterbox or assembled into a bank (see available configurations below)
- Supporting legs

STANDARDS

- Secured By Design
- TS 009:2012 - Grade 2
- EN 1303:2005 - Grade 4
- British Standard BS EN 13724

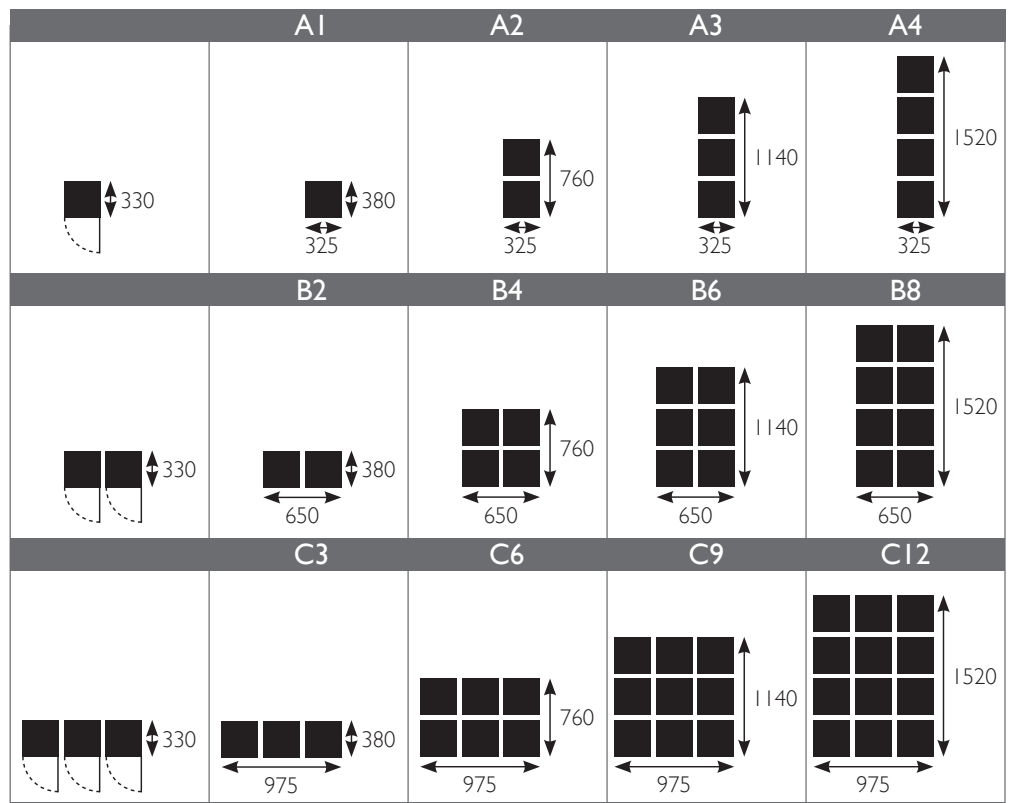



DAD GATE

The DAD Gate postal box is made of steel and powder coated in hammered black. This model is designed to be mounted behind a fence, gate or railing and suitable fixings are supplied. There is a lockable rear retrieval door and a front postal aperture to allow the safe and secure delivery of your mail without entering the premises. A perspex nameplate is also provided thus allowing personalisation.

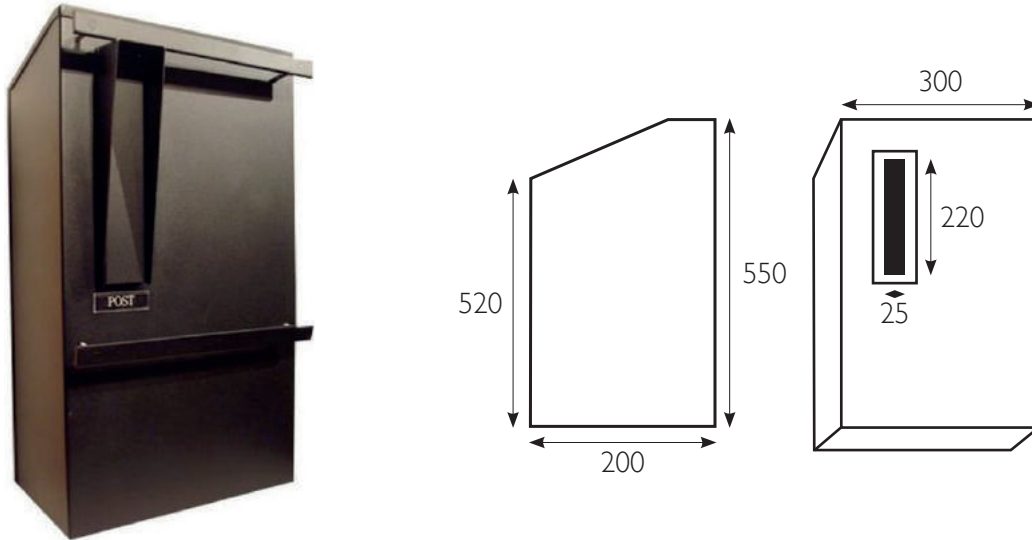

SPECIFICATIONS

- Electro-galvanized steel
- 5 Year guarantee
- Security lock complete with 2 keys

OPTIONS

- Anti-Arson device
- Permanent engraving
- Integration with a Master Key System

STANDARDS

- Conforms to Royal Mail requirements and is able to receive A4 mail





DAD PARCEL BOX

The most frustrating issue facing many online shoppers today is that they are never home to receive their parcels which won't fit through their letterplate or into their postbox. Therefore, requiring a round trip to the local sorting office to queue to collect your latest parcel or worse still having your goods delivered to your place of work!

The designer led DAD Parcel Box is the solution that we have all been looking for. A large receptacle for all your mail, newspapers and small packages. Secured within a galvanised steel box and concreted into the ground with a patented base plate and securely locked with a 5 pin cylinder. The parcel flap for deliveries is 115mm(h) x 30mm(w) x 300mm(d).



SPECIFICATIONS

- Electro-galvanized steel
- 10 Year guarantee
- 5 Pin security lock complete with 2 keys
- 100% polyester powder coated in Black
- Anti-Theft device

OPTIONS

- Integration with a Master Key System
- Vinyl lettering
- Concrete Fixing Kit

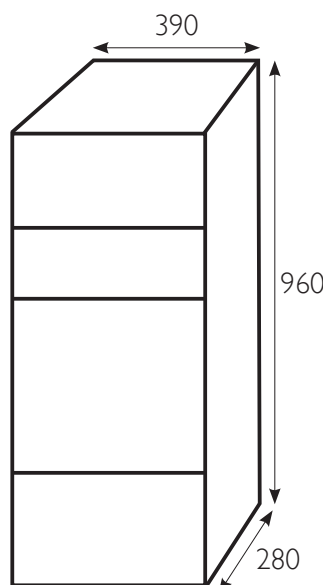

DAD Parcel Box

Width: 390mm
 Height: 960mm
 Depth: 280mm
 Volume: 105 Litres
 Parcel opening: 115 x 300 x 330



DAD ANTI-ARSON RANGE

The Anti-Arson Range is designed to extinguish a fire and contain the risk within the mailbox. The domestic version is designed to be installed on the back of a residential front door; secured in line with an existing letterplate. The commercial unit is designed to go through a wall for a front mail delivery and rear retrieval solution. All mailboxes will take standard A4 size mail.

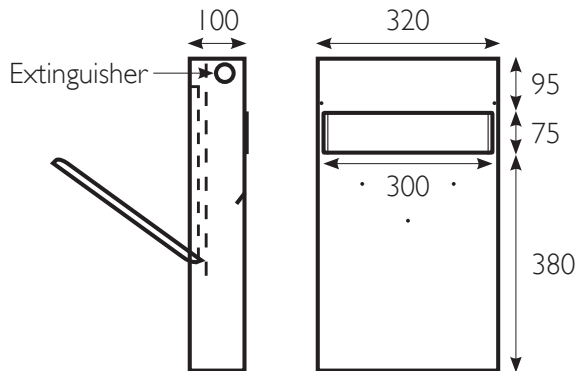

DAD Domestic Anti-Arson

Width: 320mm
 Height: 550mm
 Depth: 100mm
 Volume: 17.6 Litres
 Aperture: 300mm x 75mm



SPECIFICATIONS

- Electro-galvanized steel
- 10 Year guarantee
- Security lock complete with 2 keys
- Anti-Theft device

OPTIONS

- Integrated access control
- Digital/Electronic and Multi-locking systems
- Anti-Arson device
- Permanent engraving
- Satin Stainless Steel or Anodized Aluminium finish
- Stands and Surrounds
- Site Survey and Installation

STANDARDS

- Complies to British Standard BSEN13724
- Conforms to New Homes Guide by Secured By Design 2011 and Royal Mail requirements

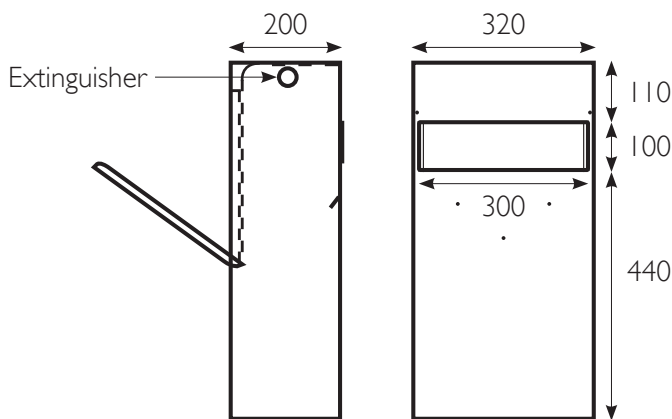

DAD Commercial Anti-Arson

Width: 320mm
 Height: 550mm
 Depth: 200mm
 Volume: 35.2 Litres
 Aperture: 300mm x 100mm



Extendable chute with letter plate
 Only sold in conjunction with Commercial Mailsafe



DAD SALTO RANGE - RFID PROXIMITY

Following the increased demand for integrated mailbox and RFID access control solutions, especially within large, multi occupancy public sector buildings, DAD and Salto have launched the DAD SALTO Mailbox. Due to the intelligent locking mechanism, they are suitable only for internal applications. All mailboxes will take standard A4 size mail.

SPECIFICATIONS

- Electro-galvanized steel
- 10 Year guarantee
- 100% polyester powder coated to any RAL
- Letter flap with sound reducing device
- Anti-Theft device

OPTIONS

- Integrated access control
- Anti-Arson device
- Permanent engraving
- Satin Stainless Steel or Anodized Aluminium finish
- Stands and Surrounds
- Site Survey and Installation

STANDARDS

- Complies to British Standard BSEN13724
- Conforms to New Homes Guide by Secured By Design 2011 and Royal Mail requirements



DAD SALTO H

Width: 400mm
Height: 165mm
Depth: 380mm
Volume: 25 Litres
Aperture: 240mm x 50mm



DAD SALTO V

Width: 375mm
Height: 320mm
Depth: 150mm
Volume: 18 Litres
Aperture: 325mm x 35mm





DAD HEAVY DUTY RANGE

The DAD Heavy Duty Range is a secure and robust collection of mailboxes. In most cases of front mail delivery and front retrieval, the mailboxes are positioned either freestanding, mounted against or recessed within a wall. They are suitable for both external and internal applications. All mailboxes will take standard A4 size mail. DAD has a wealth of experience in manufacturing high quality and secure mailboxes that are specially designed to meet the requirements of the end user.

SPECIFICATIONS

- Made from Aluminum Extrusions
- 10 Year guarantee
- Rust proof
- Security lock complete with 2 keys
- 100% polyester powder coated to any RAL
- Letter flap with sound reducing device
- Anti-Theft device

OPTIONS

- Integrated access control
- Digital/Electronic and Multi-locking systems
- Anti-Arson device
- Permanent engraving
- Integration with a Master Key System
- Stands and Surrounds
- Site Survey and Installation

STANDARDS

- Conforms to New Homes Guide By Secured by Design 2011 and Royal Mail requirements



DAD HDI

Width: 265mm
 Height: 390mm
 Depth: 125mm
 Volume: 12.9 Litres
 Aperture: 232mm x 25mm
 Weight: 2kg



DAD HDI

Width: 300mm
 Height: 150mm
 Depth: 360mm
 Volume: 16.2 Litres
 Aperture: 265mm x 25mm
 Weight: 2kg







DAD 2010 RANGE

In most cases of front mail delivery and front retrieval, the mailboxes are positioned either freestanding, mounted against or recessed within a wall. They are suitable for both external or internal applications. All mailboxes will take standard A4 size mail. DAD has a wealth of experience in manufacturing high quality and secure mailboxes that are specially designed to meet the requirements of the end user.

SPECIFICATIONS

- Electro-galvanized steel
- 10 Year guarantee
- Security lock complete with 2 keys
- 100% polyester powder coated to any RAL
- Letter flap with sound reducing device
- Anti-Theft device

OPTIONS

- Integrated access control
- Digital/Electronic and Multi-locking systems
- Anti-Arson device
- Permanent engraving
- Satin Stainless Steel or Anodized Aluminium finishes
- Integration with a Master Key System
- Stands and Surrounds
- Site Survey and Installation

STANDARDS

- Complies to British Standard BSEN13724
- Conforms to New Homes Guide by Secured by Design 2011 and Royal Mail requirements

DAD 2010-1: Standard

Width: 375mm
Height: 110mm
Depth: 280mm
Volume: 11.6 Litres
Aperture: 325mm x 35mm

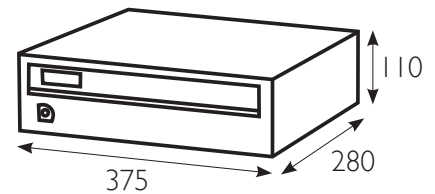

DAD 2010-16: Secure

Width: 375mm
Height: 165mm
Depth: 280mm
Volume: 17.3 Litres
Aperture: 325mm x 35mm

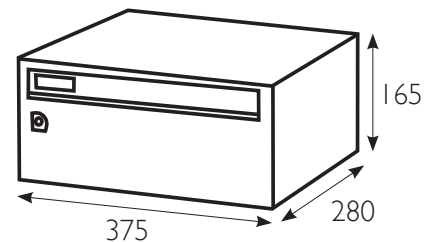

DAD 2010-2: Secure XL

Width: 375mm
Height: 220mm
Depth: 280mm
Volume: 23.1 Litres
Aperture: 325mm x 35mm

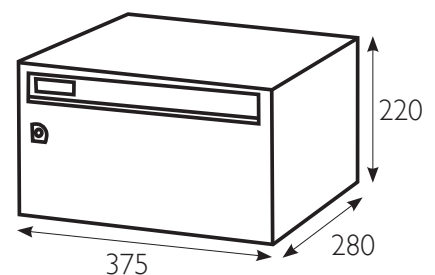

DAD 2010-3: Secure XXL

Width: 375mm
Height: 330mm
Depth: 280mm
Volume: 34.7 Litres
Aperture: 325mm x 35mm

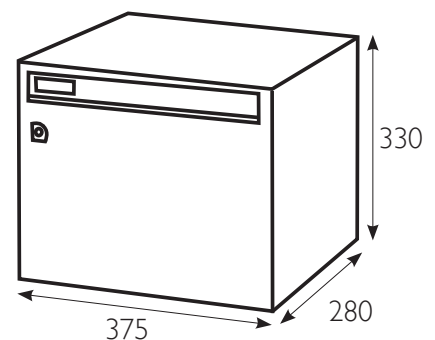





DAD 2020 RANGE

In most cases of front mail delivery and front retrieval, the mailboxes are positioned either freestanding, mounted against or recessed within a wall. They are suitable for both external or internal applications. All mailboxes will take standard A4 size mail. DAD has a wealth of experience in manufacturing high quality and secure mailboxes that are specially designed to meet the requirements of the end user.

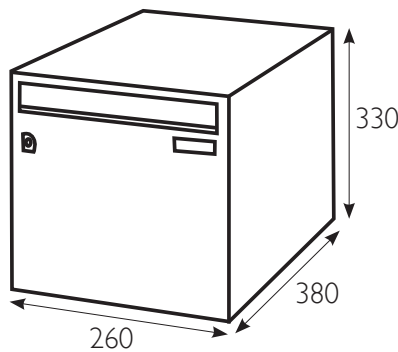
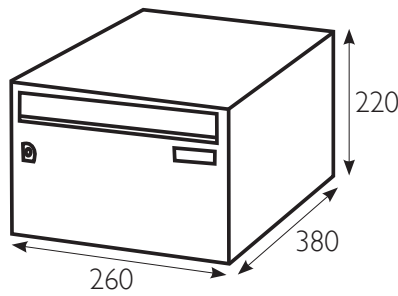
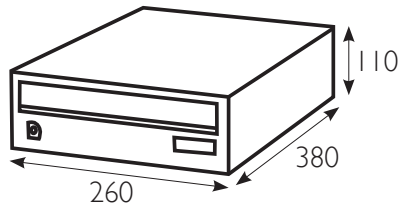

SPECIFICATIONS

- Electro-galvanized steel
- 10 Year guarantee
- Security lock complete with 2 keys
- 100% polyester powder coated to any RAL
- Letter flap with sound reducing device

OPTIONS

- Integrated access control
- Digital/Electronic and Multi-locking systems
- Anti-Arson device
- Permanent engraving
- Satin Stainless Steel or Anodized Aluminium finishes
- Integration with a Master Key System
- Stands and Surrounds
- Site Survey and Installation

STANDARDS

- Complies to British Standard BSEN13724
- Conforms to New Homes Guide by Secured by Design 2014 and Royal Mail requirements





DAD 2030 RANGE

In most cases of front mail delivery and front retrieval, the mailboxes are positioned either freestanding, mounted against or recessed within a wall. They are suitable for both external or internal applications. All mailboxes will take standard A4 size mail. DAD has a wealth of experience in manufacturing high quality and secure mailboxes that are specially designed to meet the requirements of the end user.

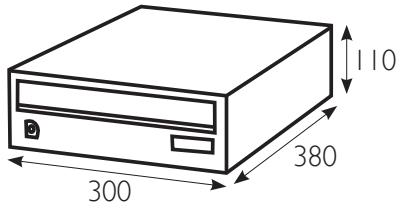

DAD 2030-1(e): Standard

Width: 300mm
 Height: 110mm
 Depth: 380mm
 Volume: 12.5 Litres
 Aperture: 260mm x 35mm

SPECIFICATIONS

- Electro-galvanized steel
- 10 Year guarantee
- Security lock complete with 2 keys
- 100% polyester powder coated to any RAL
- Letter flap with sound reducing device
- Anti-Theft device

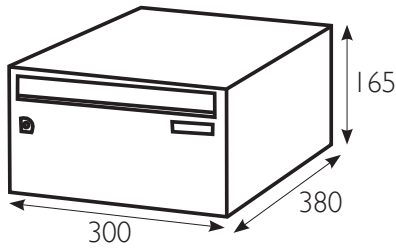

DAD 2030-16: Secure

Width: 300mm
 Height: 165mm
 Depth: 380mm
 Volume: 18.8 Litres
 Aperture: 260mm x 35mm

OPTIONS

- Integrated access control
- Digital/Electronic and Multi-locking systems
- Anti-Arson device
- Permanent engraving
- Satin Stainless Steel or Anodized Aluminium finishes
- Integration with a Master Key System
- Stands and Surrounds
- Site Survey and Installation

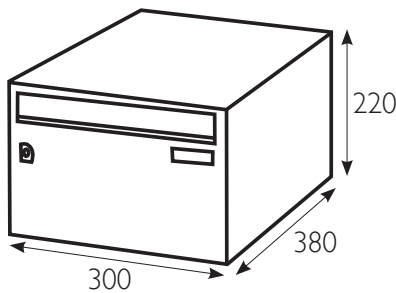

DAD 2030-2: Secure XL

Width: 300mm
 Height: 220mm
 Depth: 380mm
 Volume: 25.1 Litres
 Aperture: 260mm x 35mm

STANDARDS

- Complies to British Standard BSEN13724
- Conforms to New Homes Guide by Secured by Design 2011 and Royal Mail requirements

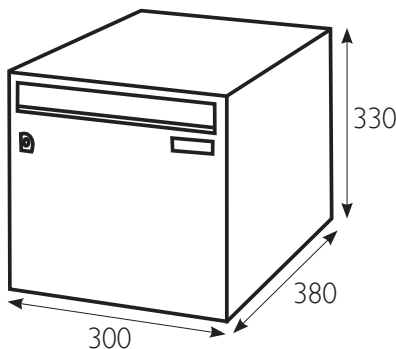

DAD 2030-2: Secure XL

Width: 300mm
 Height: 330mm
 Depth: 380mm
 Volume: 37.6 Litres
 Aperture: 260mm x 35mm

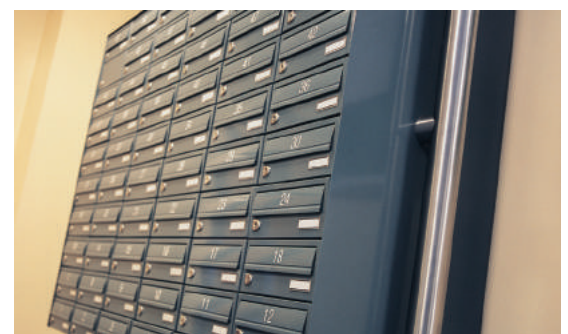



DAD 2035 RANGE

This mailbox system is the most appealing for front delivery and rear retrieval. The system can be fitted through a cavity wall, by an entrance door through a single/double glazing panel or in any frame. Its one-piece design makes the unit neat and offers the latest improvements against vandalism. Made to measure, the front plate is made of 3mm thick aluminium or stainless steel and can be adapted to any configuration.

The curved flap design enhances the appearance. Each flap has gasket seals to ensure water-tightness. The mailboxes can be adapted in finishes and sizes to suit any exterior or interior location and all come with a lockable inner door (cylinder with 2 keys). An internal anti-theft device is also fitted as standard behind the flap.

SPECIFICATIONS

- Electro-galvanized steel
- 10 Year guarantee
- Security lock complete with 2 keys
- 100% polyester powder coated to any RAL
- Letter flap with sound reducing device
- Anti-Theft device

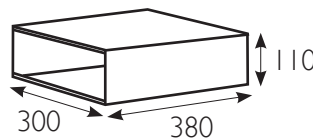

DAD 2035-1: Standard

Width: 300mm
 Height: 110mm
 Depth: 380mm
 Volume: 12.5 Litres
 Aperture: 280mm x 35mm

OPTIONS

- Integrated access control
- Digital/Electronic and Multi-locking systems
- Soft-Close flap
- Anti-Arson device
- Permanent engraving
- Satin Stainless Steel or Anodized Aluminium finishes
- Integration with a Master Key System
- Site Survey and Installation

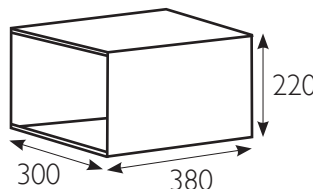

DAD 2035-2: Secure

Width: 300mm
 Height: 220mm
 Depth: 380mm
 Volume: 25.1 Litres
 Aperture: 280mm x 35mm

STANDARDS

- Complies to British Standard BS EN 13724

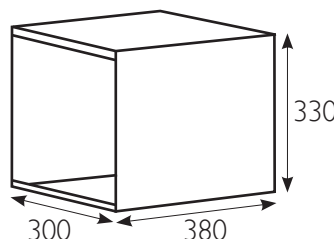

DAD 2035-3: Secure XL

Width: 300mm
 Height: 330mm
 Depth: 380mm
 Volume: 37.6 Litres
 Aperture: 280mm x 35mm



DAD 2040 RANGE

In most cases of front mail delivery and front retrieval, the mailboxes are positioned either freestanding, mounted against or recessed within a wall. They are suitable for both external or internal applications. All mailboxes will take standard A4 size mail. DAD has a wealth of experience in manufacturing high quality and secure mailboxes that are specially designed to meet the requirements of the end user.

SPECIFICATIONS

- Electro-galvanized steel
- 10 Year guarantee against complete rust
- Security lock complete with 2 keys
- 100% polyester powder coated to any RAL
- Letter flap with sound reducing device
- Anti-Theft device

OPTIONS

- Integrated access control
- Digital/Electronic and Multi-locking systems
- Anti-Arson device
- Permanent engraving
- Satin Stainless Steel or Anodized Aluminium finishes
- Integration with a Master Key System
- Stands and Surrounds
- Site Survey and Installation

STANDARDS

- Complies to British Standard BSEN 13724
- Conforms to New Homes Guide by Secured by Design 2011 and Royal Mail requirements



DAD 2040

Width: 270mm
 Height: 370mm
 Depth: 110mm
 Volume: 11 Litres
 Aperture: 230mm x 35mm

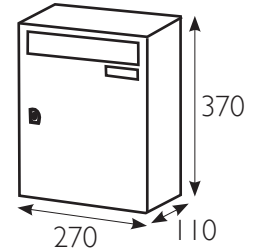

DAD 2040 XL

Width: 300mm
 Height: 440mm
 Depth: 150mm
 Volume: 19.8 Litres
 Aperture: 260mm x 35mm

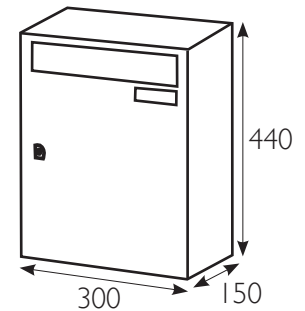

DAD 2040 XXL

Width: 375mm
 Height: 440mm
 Depth: 150mm
 Volume: 24.8 Litres
 Aperture: 325mm x 35mm

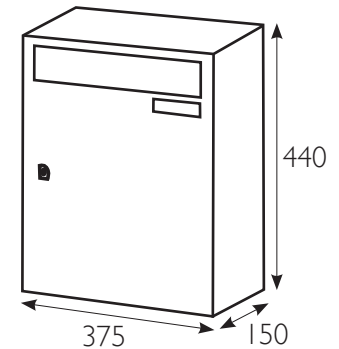



DAD 2700 RANGE

This mailbox system is the most appealing for front delivery and rear retrieval. The system can be fitted through a cavity wall, by an entrance door through a single /double glazing panel or in any frame. Its one-piece design makes the unit neat and offers the latest improvements against vandalism. Made to measure, the front plate is made of 3mm thick aluminum or stainless steel and can be adapted to any configuration.

The curved flap design enhances the appearance. Each flap has gasket seals to ensure water-tightness. The mailboxes can be adapted in finishes and sizes to suit any exterior or interior location and all come with a lockable inner door (cylinder with 2 keys). An internal anti theft device is also fitted as standard behind the flap.

SPECIFICATIONS

- Electro-galvanized steel
- 10 Year guarantee
- Security lock complete with 2 keys
- 100% polyester powder coated to any RAL
- Letter flap with sound reducing device
- Anti-Theft device

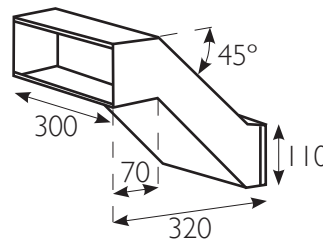

DAD 2700-1: Standard

Width: 300mm
 Height: 110mm
 Depth: 320mm
 Volume: 12.5 Litres
 Aperture: 280mm x 35mm

OPTIONS

- Integrated access control
- Digital/Electronic and Multi-locking systems
- Soft-Close flap
- Anti-Arson device
- Permanent engraving
- Satin Stainless Steel or Anodized Aluminium finishes
- Integration with a Master Key System
- Site Survey and Installation

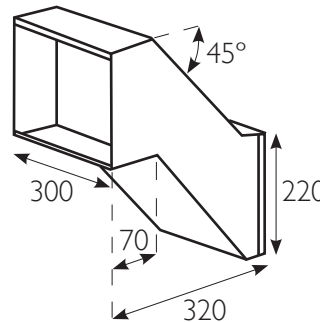

DAD 2700-2: Secure

Width: 300mm
 Height: 220mm
 Depth: 320mm
 Volume: 25.1 Litres
 Aperture: 280mm x 35mm

STANDARDS

- Complies to British Standard BS EN 13724
- Conforms to New Homes Guide by Secured by Design 2011 and Royal Mail requirements

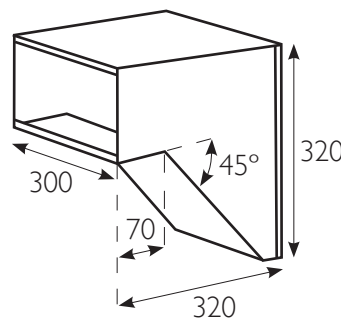

DAD 2700-3: Secure XL

Width: 300mm
 Height: 320mm
 Depth: 320mm
 Volume: 37.6 Litres
 Aperture: 280mm x 35mm







DAD TELESCOPIC SLOPING RANGE

The DAD Telescopic range was developed to suit all through the wall requirements. This range is available in two depths and heights and comes with a fully opening door at the rear whilst sitting flush with the inner wall. Available as a multi unit we are able to offer any configuration to suit your individual requirements. In addition to our standard RAL colour range you can choose from over 250 RAL colours and anodised aluminium finishes.

DAD has a wealth of experience in manufacturing high quality mailboxes that are specially designed to meet the requirements of the end user. We have a full comprehensive range of entry systems and intercoms that can also be integrated into any of our mailbox systems and engraving is also available on the flaps or doors, alternatively an engraved Perspex nameplate can be provided.

SPECIFICATIONS

- Electro-galvanized steel
- 10 Year guarantee
- Security lock complete with 2 keys
- 100% polyester powder coated to any RAL
- Letter flap with sound reducing device
- Anti-Theft device

OPTIONS

- Integrated access control
- Digital/Electronic and Multi-locking systems
- Soft-Close flap
- Anti-Arson device
- Permanent engraving
- Satin Stainless Steel or Anodized Aluminium finishes
- Integration with a Master Key System
- Stands and Surrounds

STANDARDS

- Complies to British Standard BSEN 13724
- Conforms to New Homes Guide by Secured by Design 2011 and Royal Mail requirements

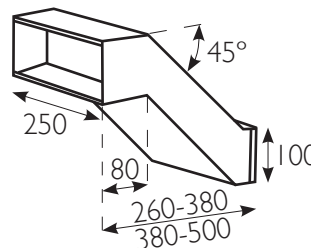

DAD 2000

Width: 250mm
 Height: 100mm
 Depth: 260mm - 380mm
 380mm - 500mm
 Volume: 6.5 - 12.5 Litres
 Aperture: 230mm x 35mm

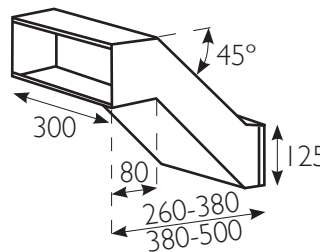

DAD 2001

Width: 300mm
 Height: 125mm
 Depth: 260mm - 380mm
 380mm - 500mm
 Volume: 9.5 - 18.5 Litres
 Aperture: 280mm x 35mm

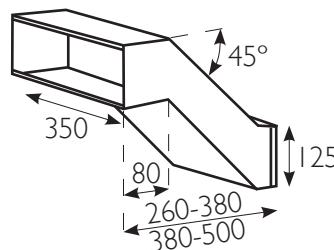

DAD 2002

Width: 350mm
 Height: 125mm
 Depth: 260mm - 380mm
 380mm - 500mm
 Volume: 11 - 21.5 Litres
 Aperture: 330mm x 35mm



NORWICH

61-67 St. Benedicts Street,
Norwich, NR2 4PD
Tel: 01603 216500
Fax: 01603 216510
Email: sales@acleigh.co.uk

COLCHESTER

11 Grange Way,
Whitehall Industrial Estate,
Colchester, CO2 8HG
Tel: 01206 877488
Fax: 01206 877480
Email: colchester@acleigh.co.uk

IPSWICH

Unit 2-3, Dencora Business Centre,
Whitehouse Road, Ipswich, IPI 5LT
Tel: 01473 292810
Fax: 01473 292818
Email: ipswich@acleigh.co.uk

SECURITY

61-67 St. Benedicts Street,
Norwich, NR2 4PD
Tel: 01603 216501
Fax: 01603 216514
Email: security@acleigh.co.uk

www.acleigh.co.uk