

Bolt

Fix 575

Used on side-hung doors, which are operated from the outside, inside or both.

Operation and features

Two point locking which can be supplemented with one or more side bolts, Fix 244, page J 196. Fits both right and left versions, by moving the stop link of the lock housing. The stop link limits the handle movement between open and closed positions. Travel is 28 mm for each bolt bar. Fix 575 is prepared for locking from the inside with a pushbutton cylinder, Fix 2940, page H 165.

Construction

- Lock housing.
- Bolt bars, 13 mm square.
- Bar guides.
- Inner handle.
- Outer handle.

Material

Rower and handle bearing of zinc-aluminium.
Other parts of galvanized steel.

Installation

Surface mounting. Mounting instructions are included in the lock housing package.

Standard lengths

2075, 2475, 2975 mm. Handle height 1100 mm.

Measurements relate to mounted bolt in open position.

Total length of the upper bar (Fix 723): 939 mm (Fix 0723 3093), 1339 mm (Fix 0723 3133), 1839 mm (Fix 0723 3183). Total lower bar length: 1064 mm (Fix 0722, 3106). Upper bar end bevelled and bent 7 mm. Lower bar end is turned and bent 7 mm.

Accessories

Outer handle Fix 1710, of zamak, powder painted grey, see below.
Inner handle Fix 2858, of galvanized steel.
Grab bolt Fix 564, page J 196. Side bolt Fix 244, page J 196.
Bar guide Fix 354/13, page J 193, 2 pcs. included in lock housing package.

Receiver Fix 351/13, page J 197, 1 pcs. included in the lock housing package.
Receiver Fix 352/13, 353/13, 1847, page J 197.
Pushbutton cylinder Fix 2940, page H 165.

When ordering, please state:

- Standard length, or for made-to-measure: total bolt length (mounted and in open position), and handle height (from bottom edge of bar to centre of handle row).
- Handle item number.
- Other accessories.

Unless otherwise ordered, delivery includes made-to-measure bolt with bar adaption like description for standard lengths. But for inward-opening doors, unbent upper bars are supplied.

Screw

For lock housing
no. 9 (4.5 mm) TKX / DIN 7995.
For bar guide and receiver 351
no. 9 (4.5 mm) TKX / DIN 7996.
For handle 1710
no. 8 (4.0 mm) TKF / DIN 7995.
For grab bolt 564 and side bolt 244
no. 12 (5.5 mm) TKX / DIN 7996.
For receiver 353
no. 10 (5.0 mm) TKX / DIN 7996.

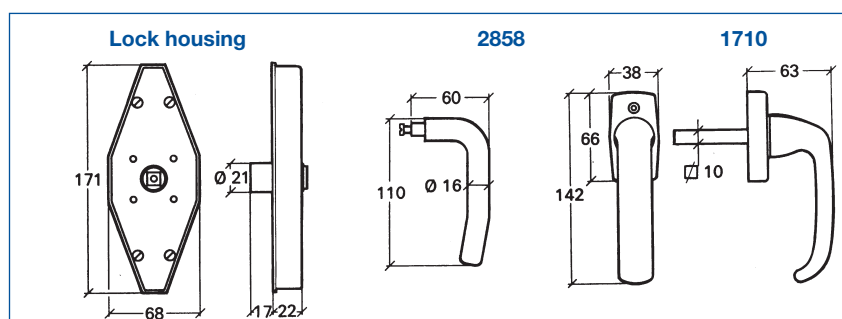
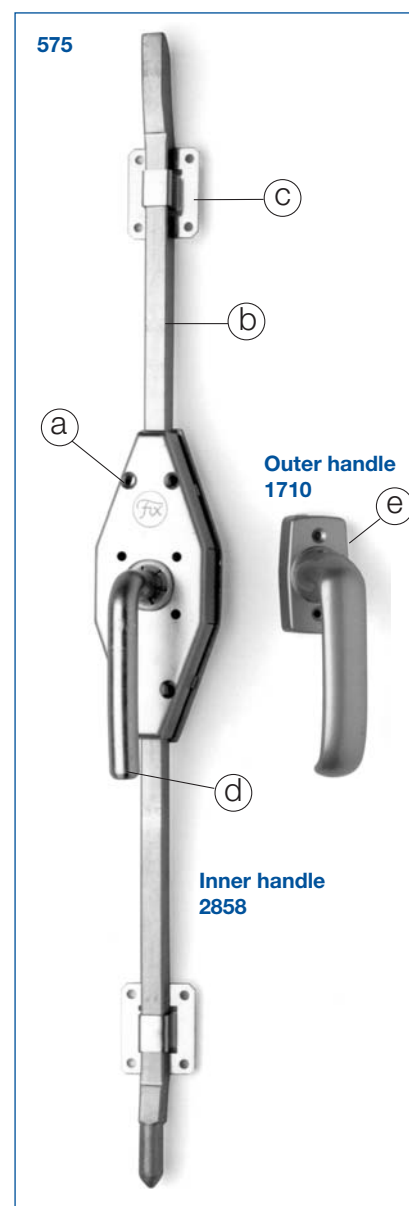

560/13
560/19
560L/19

Bolts Fix 560/13, 560/19, 560L/19

Used for side-hung doors, which are operated from the inside only.

Operation and features

Two point locking. Fix 560/13 can be supplemented with one or more side bolts, Fix 244, page J 196. Fits both right and left versions by moving the stop link of the lock housing. The stop link limits the handle movement between open and closed positions.

Travel for each bolt bar is:

28 mm for Fix 560/13.

39 mm for Fix 560/19.

Fix 560/13 is prepared for locking from the inside with pushbutton cylinder Fix 2940, page H 165.

Fix 560/13 can also be used as panic bolt.

In this case, the lock housing is mounted without stop link with the handle pointing up in closed position. Suitable handle height is 1600 mm.

Bolt Fix 560L/19

Operation and features like Fix 560/19, but also lockable from the inside with oval cylinder of standard type.

Construction

- a) Lock housing.
- b) Bolt bars
 - 13 mm square for Fix 560/13
 - 19 mm square for Fix 560/19 and 560L/19.
- c) Bar guides.
- d) Lockable handle.

Material

Brass handle bearing.

Lockable handle for Fix 560L/19 of zamak, powder painted black, and with plate of black acetal plastic.

Other parts of galvanized steel.

Installation

Surface mounting.

Mounting instructions are included in the lock housing package.

Standard lengths

For Fix 560/13: 2075, 2475, 2975 mm.

For Fix 560/19 and 560L/19: 3500 mm.

Handle height for all 1100 mm

Measurements relate to mounted bolt in open position.

Total length of upper bar for Fix 560/13:
939 mm (Fix 0723 3093), 1339 mm (Fix 0723 3133), 1839 mm (Fix 0723 3183).

Total length of lower bar for Fix 560/13:
1064 mm (Fix 0722 3106).

Total length of upper bar for

Fix 560/19 and 560L/19: 2361 mm (Fix 0723 9236).

Total length of lower bar for Fix 560/19 and 560L/19:

1061 mm (Fix 0722 9106).

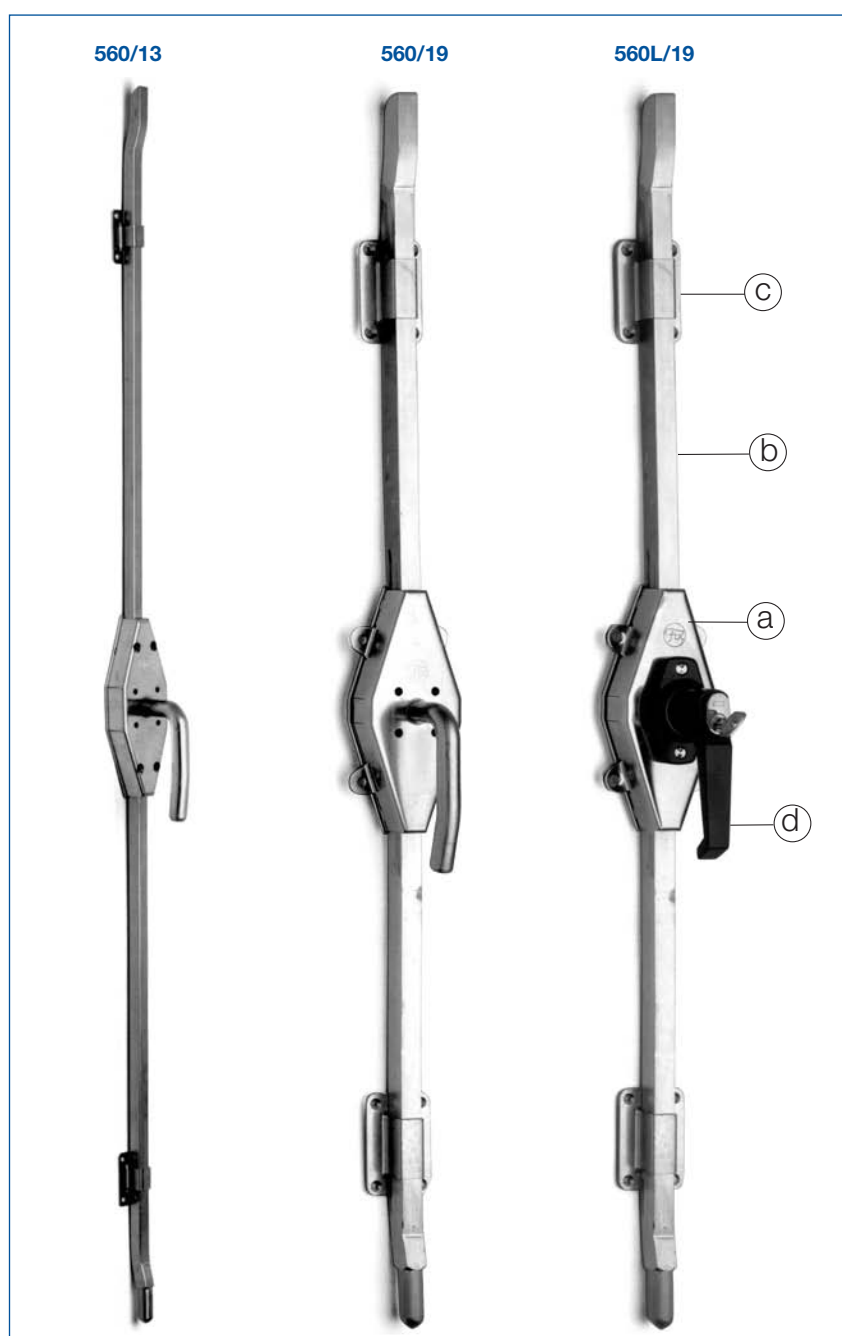

Bolt measurement drawings

Accessories

Grab bolt Fix 564 for Fix 560/13, page J 196.
 Side bolt Fix 244 for Fix 560/13, page J 196.
 Bar guide Fix 354, page H 165, 2 pcs. included in lock housing package. Receiver, page J 197 (1 pc. Fix 351 included in lock housing package). Pushbutton cylinder Fix 2940 for Fix 560/13, page H 165.
 For Fix 560L/19: oval cylinder of standard type.

When ordering, please state:

1. Item number.
2. Standard length, or for made-to-measure: total bolt length (mounted and in open position), and handle height (from bottom edge of bar to centre of handle rower).
3. Other accessories.

Unless otherwise ordered, made-to-measure bolt with bar adaption like the description for standard lengths will be supplied. But for inward-opening doors, unbent upper bars are delivered.

Screw

For lock housing 560/13
 no. 9 (4.5 mm) TKX / DIN 7995.
 For lock housing 560/19, 560L/19
 no. 12 (5.5 mm) TKX / DIN 7996.
 For bar guide 354/13
 no. 9 (4.5 mm) TKX / DIN 7996.
 For bar guide 354/19
 no. 12 (5.5 mm) TKX / DIN 7996.
 For receiver 351/13
 no. 9 (4.5 mm) TKX / DIN 7996.
 For receiver 351/19
 no. 12 (5.5 mm) TKX / DIN 7996.
 For receiver 353/13
 no. 10 (5.0 mm) TKX / DIN 7996.
 For receiver 353/19
 no. 12 (5.5 mm) TKX / DIN 7996.
 For grab bolt 564
 no. 12 (5.5 mm) TKX / DIN 7996.
 For side bolt 244
 no. 12 (5.5 mm) TKX / DIN 7996.

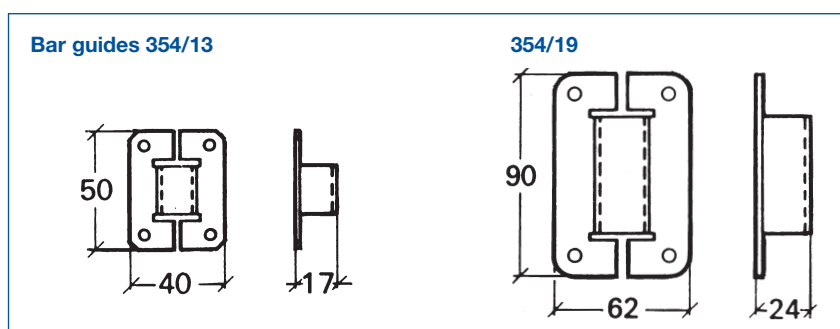
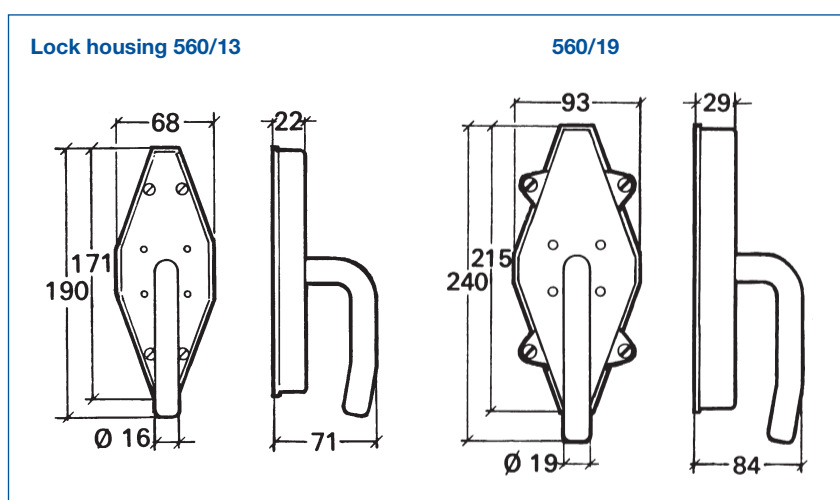

Bolts

Fix 280 and 280L

Used on side-hung doors, which are operated from both sides and lockable from the outside, or from both sides.

Operation

With the turn catch in vertical position, the bolt locks automatically when closing. Unlocking is done: from the outside with a key, from the inside by turning the turn catch to a horizontal position.
Fix 280L, lockable both sides. With the key taken out on the cylinder side, locks automatically when closing.

Features

Two point closing, which can be supplemented with one or more side bolts Fix 244, page G6. The handle has marked stop positions for both open and closed. The bolt is lockable with oval cylinder of standard type. Travel is 28 mm for each bolt bar.

Construction

- a) Inner lock housing.
- b) Outer handle.
- c) Bolt bars, 13 mm square.
- d) Bar guides.
- e) Handle pin.
- f) Cylinder shackle with screw.
- g) Screw for outer handle.

Material

Inner handle and turn catch of zamak. Cover of varnished aluminium. Rower of zinc-aluminium. Outer handle of chrome plated brass. Other parts of galvanized steel.

Installation

Surface mounting. Mounting instructions are included in the lock housing package.

Standard lengths

2100, 2500, 3000 mm. Handle height 1100 mm. Measurements relate to mounted bolt in open position.

Total upper bar length: 939 mm (Fix 0723 3093), 1339 mm (Fix 0723 3133), 1839 mm (Fix 0723 3183).

Total lower bar length: 1064 mm (Fix 0722 3106).

Upper bar end bevelled and bent 7 mm. Lower bar end is turned and bent 7 mm.

Accessories

Grab bolt Fix 564, J 196. Side bolt Fix 244, page J 196. Bar guide Fix 354/13, page J 193, 2 pcs. included in lock housing package. Receiver Fix 351/13, page J 197, 1 pc. included in lock housing package. Alternative receivers, page J 197. Oval cylinder of standard type.

When ordering, please state:

1. Standard length, or made-to-measure: total bolt length (mounted and in open position), and handle height (from bottom edge of bar to centre of handle rower).
 2. When made-to-measure bolt is to have side bolts only: measurements A and B according to illustration, page J 196.
 3. If the door is right- or left-hung.
 4. Accessories.
- Unless otherwise ordered, made-to-measure bolt with bar adaption like description for standard lengths will be supplied. But for inward-opening door, unbent upper bar is supplied.

Screw

For lock housing and bar guides no. 9 (4.5 mm) TKX / DIN 7996.
For grab bolt and side bolt no. 12 (5.5 mm) TKX / DIN 7996.
For receiver 351 no. 9 (4.5 mm) TFX / DIN 7997.
For receiver 353 no. 10 (5.0 mm) TKX / DIN 7996.

Outer handle 664 (supplied without cylinder)

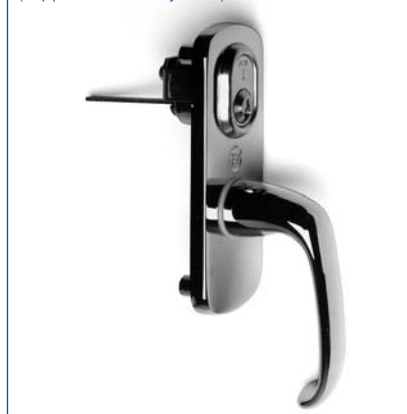

280 L



280 H

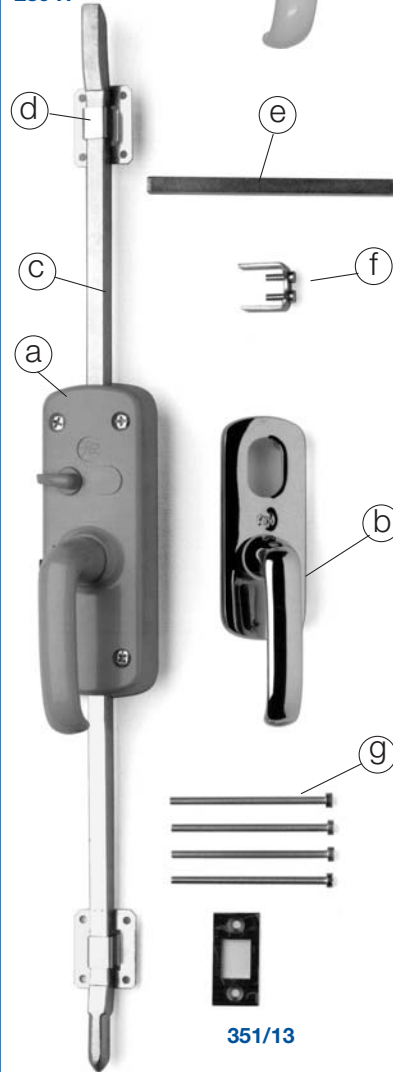

Panic bolt

Fix 285

Used for outward-opening, side-hung doors to premises where quick evacuation may be necessary.

Operation

The bolt can always be opened from the inside, even when it is locked from the outside. When closed, the inner handle is to be horizontal. For emergency evacuation, the handle is pressed down. The handle has a length, which enables manipulation with knee or elbow, for example.

Features

Two point closing, which can be supplemented with one or more side bolts Fix 244, page J 196. The handle has marked stop positions for both open and closed. The bolt is lockable with oval cylinder of standard type. Travel is 28 mm for each bolt bar.

Construction

- a) Inner lock housing.
- b) Inner handle.
- c) Outer handle.
- d) Bolt bars, 13 mm square.
- e) Bar guides.
- f) Handle pin.
- g) Cylinder shackle with screw.
- h) Screw for outer handle.

Material

Cover and inside handle of aluminium. Rower of zinc-aluminium. Outer handle of chrome plated brass. Other parts of galvanized steel.

Installation

Surface mounting. Mounting instructions are included in the lock housing package.

Standard lengths

2100, 2500, 3000 mm. Handle height 1100 mm. Measurements relate to mounted bolt in open position.

Total upper bar length: 939 mm (Fix 0723 3093), 1339 mm (Fix 0723 3133), 1839 mm (Fix 0723 3183).

Total lower bar length: 1064 mm (Fix 0722 3106).

Upper bar end bevelled and bent 7 mm. Lower bar end is turned and bent 7 mm.

Accessories

Grab bolt Fix 564, page J 196. Side bolt Fix 244, page J 196. Bar guide Fix 354/13, page J 193, 2 pcs. included in lock housing package. Receiver Fix 351/13, page J 197. 1 pc included in lock housing package. Alternative receivers, page J 197.

Oval cylinder of standard type.

When ordering, please state:

1. Standard length, or for made-to-measure: total bolt length (mounted and in open position), and handle height (from bottom edge of bar to centre of handle row).

2. When made-to-measure bolt is to have side bolts only: measurements A and B according to illustration, page J 196.

3. If the door is right- or left-hung.

4. Accessories.

Unless otherwise ordered, made-to-measure bolt with bar adaption like description for standard lengths will be supplied.

Screw

For lock housing and bar guide no. 9 (4.5 mm) TKX / DIN 7996.

For receiver Fix 351

no. 9 (4.5 mm) TFX / DIN 7997.

For grab bolt and side bolt

no. 12 (5.5 mm) TKX / DIN 7996.

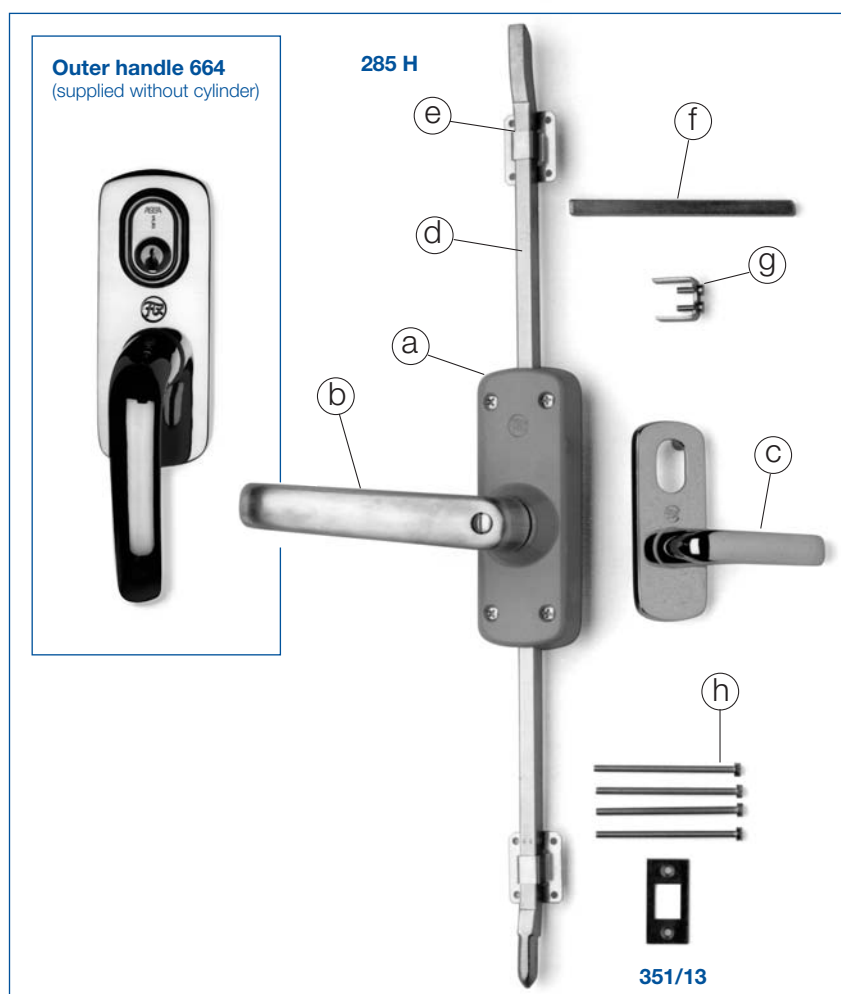

Accessories for bolts, measurement drawings

285 with side bolts 244

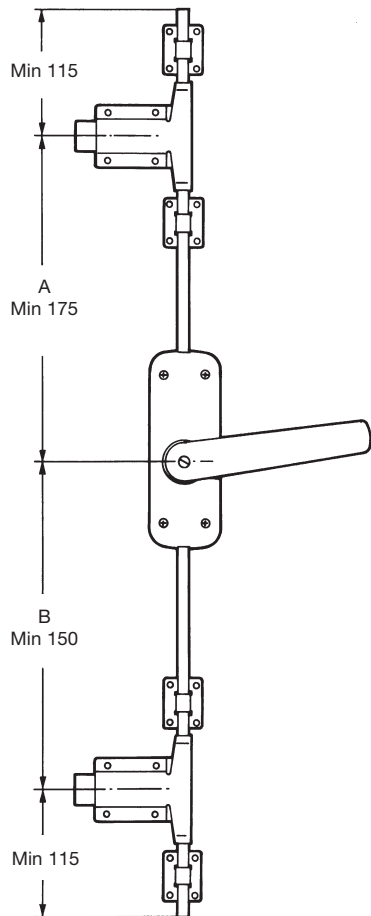

Lock housing 285 with inner handle 2530

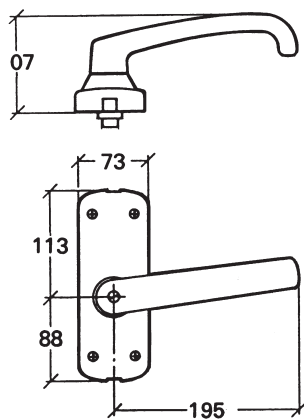

Side bolt Fix 244

For bolt with 13 mm square rods, Fix 280, 285, 560/13, 575.

Installation

Coupled to hole 7.3 mm in the bolt bar and can have optional position, see illustration. Travel 17 mm.

Material

Brass bolt. Other parts of galvanized steel.

Accessories

Bar guide Fix 354/13, see illustration, 2 pcs. included.

Screw

Use no. 12 (5.5 mm) TKX / DIN 7996.

244

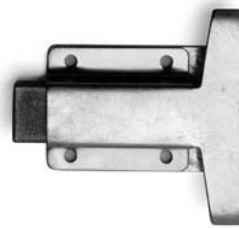

Grab bolt Fix 564

On outward-opening door for bolt with 13 mm square rods, Fix 280, 285, 560/13, 575.

Installation

Coupled to hole \varnothing 7.3 mm in straight-cut rod end. Matching glide plate is mounted in connection with the grab bolt fixing plate.

Material

Bolt and fixing plate of galvanized iron. Other parts of galvanized steel.

Screw

Use no. 12 (5.5 mm) TKX / DIN 7996.

244

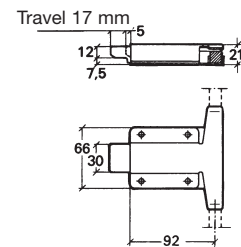

564



564

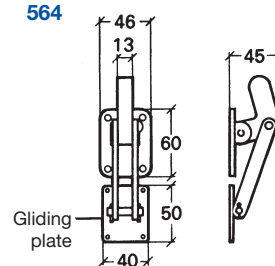

Bar guide 354/13

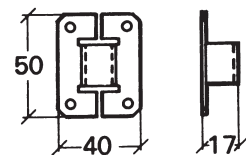

Inner lock housing 280

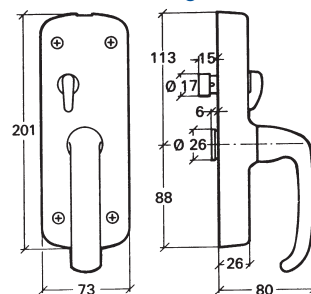

Outer handle 664

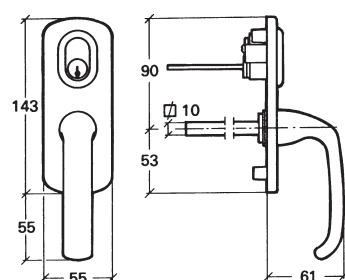

Receivers, use, measurement drawings

Use

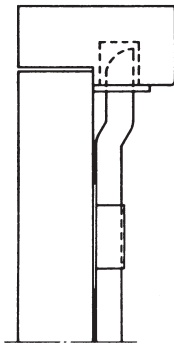

Outward-opening, wooden frame
Receiver 351

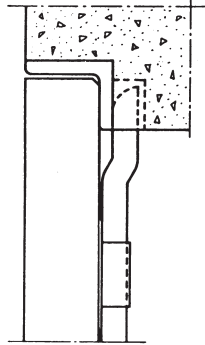

Outward-opening, angled iron frame
Receiver not necessary

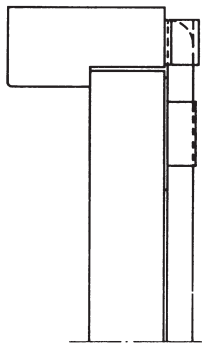

Inward-opening, wooden frame
Receiver 353

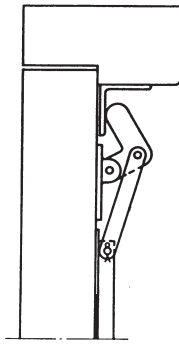

Outward-opening, wooden frame
Grab bolt 564
Receiver 1847

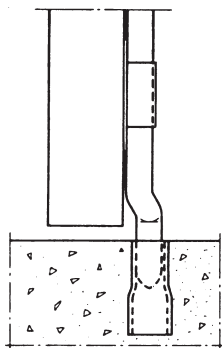

Cast flat floor
Receiver 352

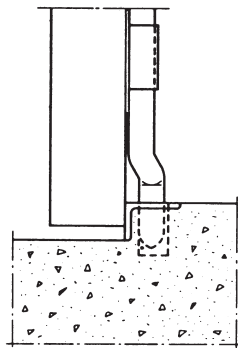

Angled iron connection
Receiver not necessary

Receivers

351/13

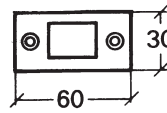

351/19

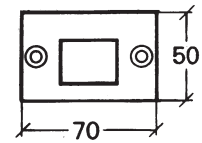

352/19



352/13

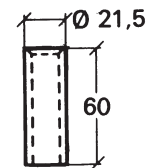

353/13

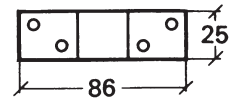

353/19

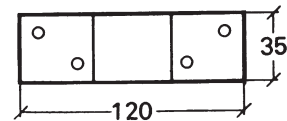

1847

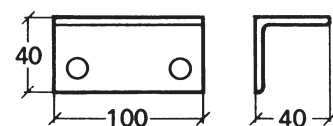

Material

All receivers of galvanized steel

Bolt

Fix 690

Used on larger or heavier doors, which are operated from the outside, inside or both.

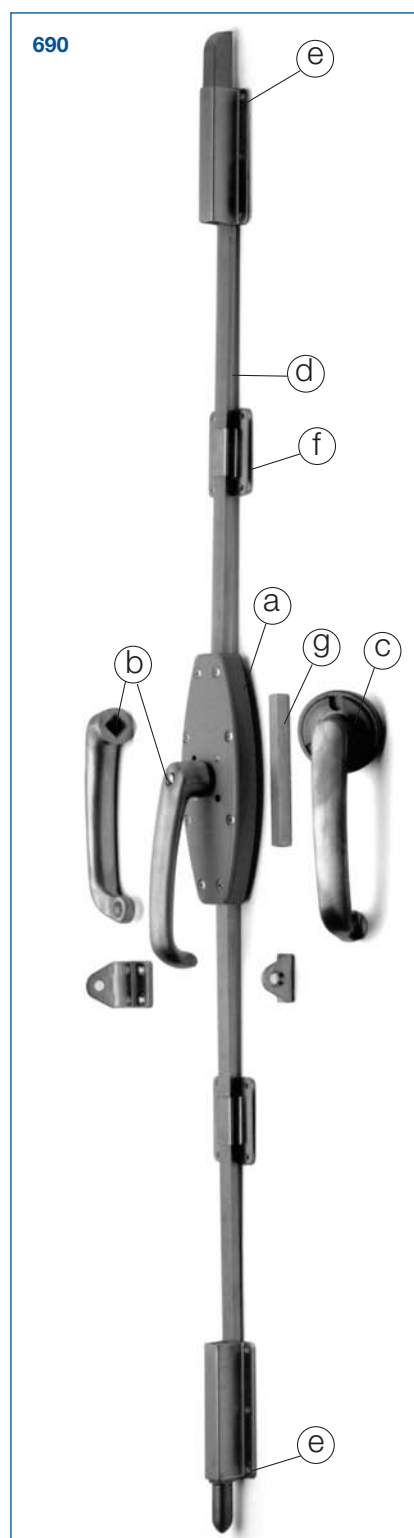

Operation and features

Two point locking. Handle may be mounted on outside, inside or both. Locking can be done with padlock on outside or inside. The outer handle fixing plate is designed to make the fitting screws inaccessible when the bolt is locked. Fits both right and left by moving the stop pin of the lock housing. The stop pins limit the handle movement between open and closed positions. Travel for each bolt bar is 44 mm.

Construction

- a) Lock housing.
- b) Inner handle.
- c) Outer handle.
- d) Bolt bars, 20 x 8 mm.
- e) End bolts 20 x 20 mm, with bolt guide.
- f) Bar guides.
- g) Handle pin.

Material

Lock housing of zamak, powder painted, grey.
Rower of zinc-aluminium. Handle of aluminium. Other parts of galvanized steel.

Installation

Surface mounting.

Standard lengths

2050, 3100 and 4000 mm. Handle height 1200 mm.
Measurements relate to mounted bolt in open position. Total upper bar length: 740 mm (2553 0740), 1790 mm (2553 1790), 2690 mm (2553 2690). Total lower bar length: 1090 mm (2553 1090).

Accessories

See page J 199.

When ordering, please state:

1. Standard length, or for made-to-measure: total bolt length (mounted and in open position), and handle height (from bottom edge of bottom bolt to centre of handle rower).
2. Handles, see page J 199.
3. Bolts, see page J 199.
4. Receivers, see page J 199.

Screw

For lock housing, bolt guide, bar guide and receiver 3085
no. 12 (5.5 mm) TKX / DIN 7996.
For outer handle, lock brackets, and receiver 351/19
no. 12 (5.5 mm) TFX / DIN 7997.
For grab bolt 356
no. 14 (6.0 mm) TKX / DIN 7996.

Bolt Fix 690, Accessories and measurement drawings

Use of bolts and receivers

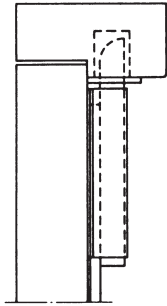

Outward-opening, wooden frame
Bolt 2548
Receiver 351/19

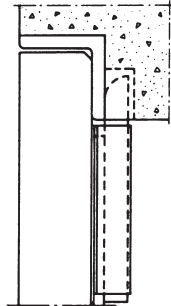

Outward-opening, angle iron frame, bolt 2548
Receiver not necessary

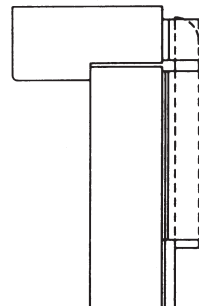

Inward-opening, wooden frame
Bolt 2548
Receiver 3085

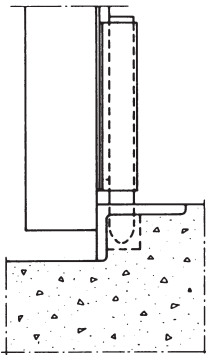

Angled iron connection
Bolt 2547
Receiver not necessary

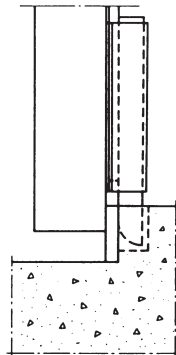

Flat iron connection
Bolt 2548
Receiver not necessary

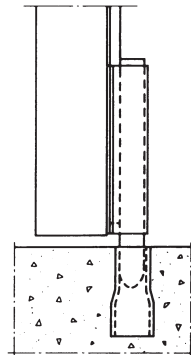

Flat even floor
Bolt 2547
Receiver 352/19

Lock housing 690

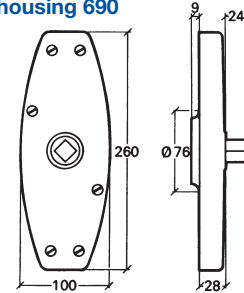

Inner handle 2530, 2540

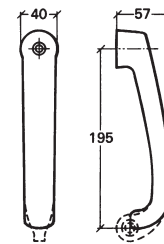

Outer handle 2550

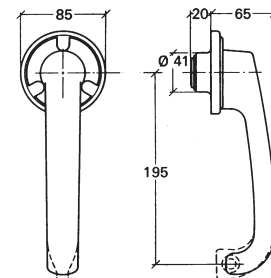

Bolt guide 2556

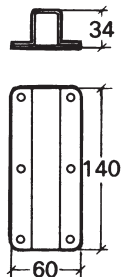

Bar guide 2554

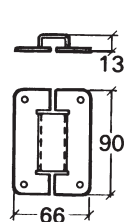

Lock bracket 2555 for handle 2550

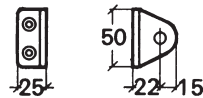

Lock bracket 2558 for handle 2540

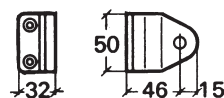

Receiver

351/19

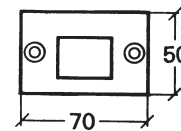

352/19

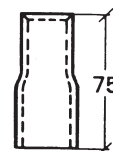

3085

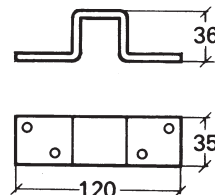

700
705

Bolts

Fix 700 and 705

Used for overhead garage doors (up and over).
Lockable with cylinder from the outside.

Inner lock housing 1115

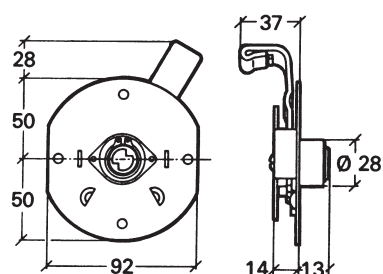

Fix 700 locked manually with key.
Fix 705 locked automatically when closing.

Operation and features

The spring-operated end bolts snap in behind the frame connection iron and provides two point locking. The key can be taken out in both unlocked and locked positions. From the inside, the bolt can always be opened with the lock housing manipulation arm. The bolt length can be adjusted by turning the end bolt pulling rod. Travel is 18 mm for each bolt.

Pull handle 4709

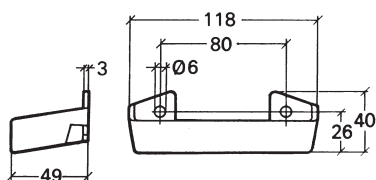

Construction

- Lock housing with manipulation arm.
- Pull handle.
- Bolt rod 12 x 3,5 mm.
- Rod guides.
- Spring-operated end bolts.
- Outer handle.

Material

Outer handle of zamak with powder painted grip and plate with cover of acetal plastic. End bolt of zamak. Rod guide of acetal plastic. Other parts of galvanized steel.

Installation

Surface mounting.
Mounting instructions are included in the lock housing package.

Standard length

2600 mm. Measurement relates to mounted bolt in open position. Lock housing centre.
Total rod length: 1200 mm (Fix1195 0120)

Accessories

Oval cylinder, standard type.
Cover plates Fix 1125/1126, page J 201.

When ordering, please state:

- Standard length, or for made-to-measure: total bolt length (mounted and in open position).
- Door thickness.

Screw

For lock housing, pulling handle and bolts no. 12 (5.5 mm) TKX / DIN 7996.
For rod guides no. 7 (3.8 mm) TKX / DIN 7996.

Note: For increased protection against forced entry, use Fix 280, page J 194.

700

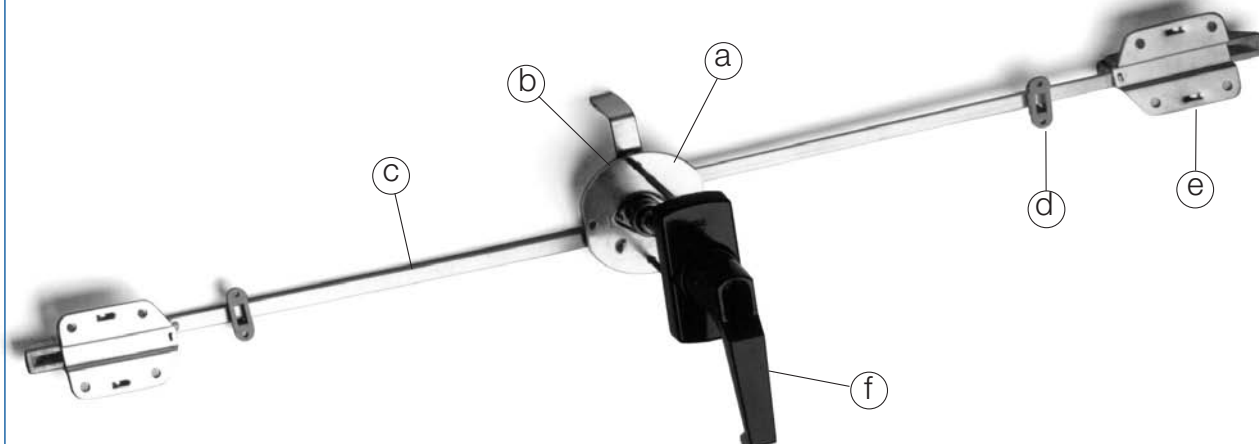

Bolts Fix 700 and 705, measurement drawings, accessories

700
705

Outer handle 1100, 1105
(supplied without cylinder)



Outer handle 1100
Locked manually

Outer handle 1105
Locked automatically

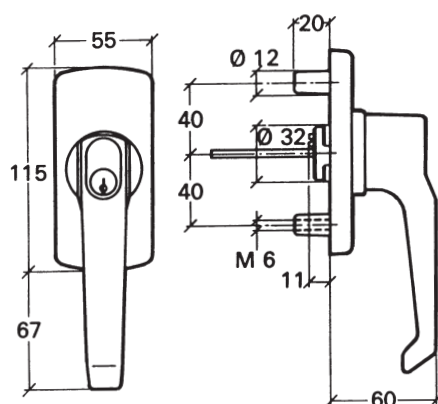

End bolt 1185

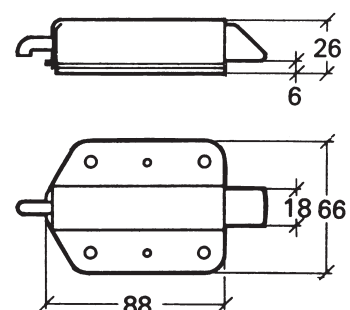

Rod guide 1191

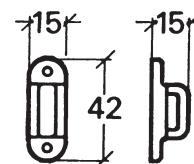

Security cover Fix 1120

Protection against forced entry for the outer handle on the garage bolt Fix 700.

Operation and features

The security cover is mounted with penetrating screw over the outer handle for garage bolt Fix 700. Then, the handle is only accessible from one side and is thereby protected against attempted forced entry.

The cover also protects the cylinder against water and frost.

Material

Steel, 3 mm, powder painted, black. Screw, nut and plate of galvanized steel included, for door thickness max 70 mm.

Dimension

H = 295 mm
W = 75 mm
D = 75 mm
c/c screw hole 274 mm



Cover plate, outer handle 1125

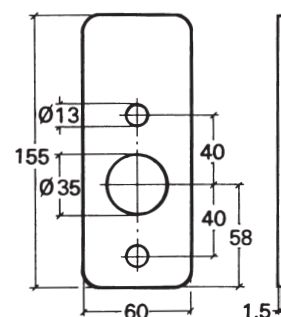

Cover plate, inner lock housing 1126

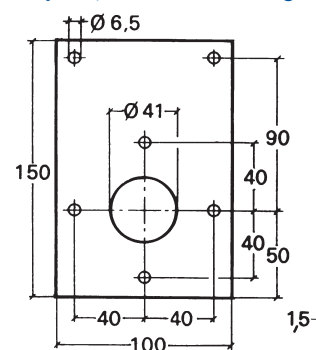

110
115

Door locks

Fix 110 and 115

Used for doors, side-hung type, ceiling-hung sliding doors, overhead garage doors (up and over), storage room doors, etc.

Fix 110: lockable with oval cylinder of standard type.
Fix 115: lockable with Europe-profile cylinder.

Operation and features

The lock is operated with key or handle. Can be locked with cylinder from outside/inside, or both. Stroke 50 mm. Available in right and left version.

Construction

- a) Lock housing.
- b) Spacer ring, for mounting of cylinder/handle on the inside.
- c) Spacer plate, for mounting of cylinder on the outside (not included).
- d) Receiver (not included).

Material

Lock housing and bolt of galvanized steel, with rower of zamak.
Spacer ring of acetal plastic.
Spacer plate of zinc-aluminium.

Installation

Can be mounted according to figure below, depending on desired key/handle movement. Mounting instructions on the package.

Accessories

Receiver Fix 5419, 5420 and 923.
Spacer plate C, see table (ordered from ASSA).
Positioning plate Fix 5135

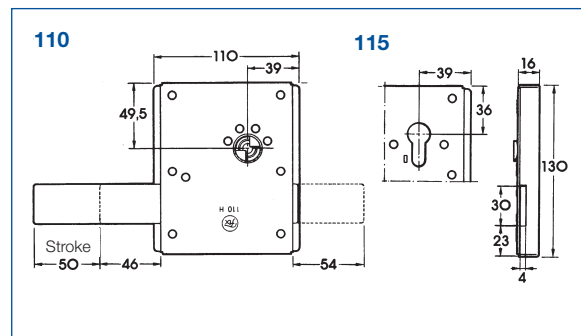
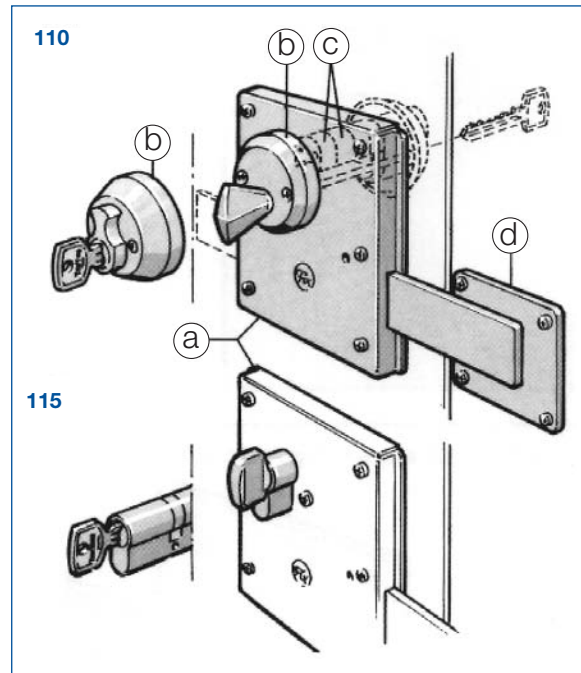
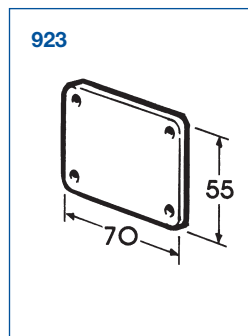
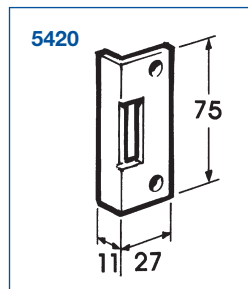
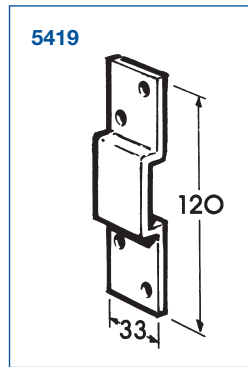

Spacer plate C	Item no. for ASSA
8 mm	41 86 81
10 mm	80 74 25
12.5 mm	41 86 82
18 mm	1 86 83

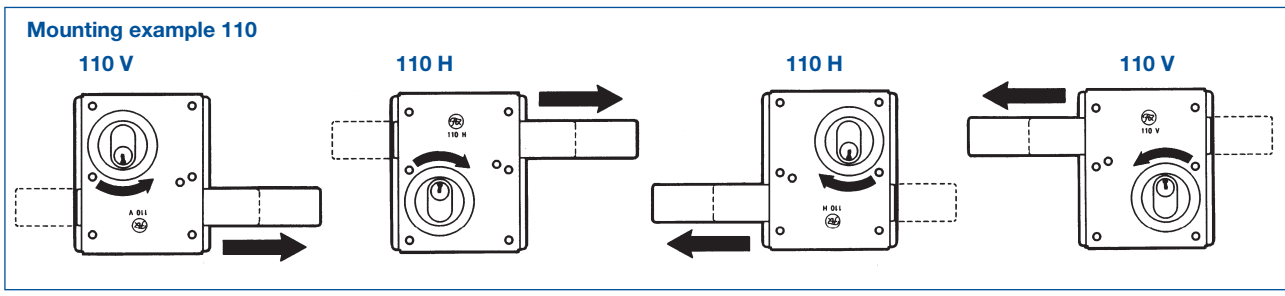

Door locks

Fix 450 and 480

Used for doors, which are operated from both sides.
Lockable with cylinder. Intended for built-in mounting.

Fix 450: lockable with Europe-profile cylinder.

Fix 480: lockable with oval or round cylinder of standard type, 360° turn. Also available with micro switch.

Operation and features

Two point closing, with coupling of tube/rods (not included). Handle may be mounted on outside, inside or both. Locking with cylinder may be done from one side or both. Fits both right and left. Travel for each bolt bar is 25 mm. Handle rower 10 mm square.

Construction

- a) Lock housing.
- b) Rod coupling.
- c) Handle rower.
- d) Lock rower.

Material

Lock housing of galvanized steel. Rod coupling of galvanized steel, diameter 12 mm. Handle and lock rower of zinc-aluminium.

Installation

Intended for built-in mounting.

Accessories

Handle Fix 1710, page J 191.

Lock cylinder:

For Fix 480, round or oval of standard type.

For Fix 450, Europe-profile cylinder.

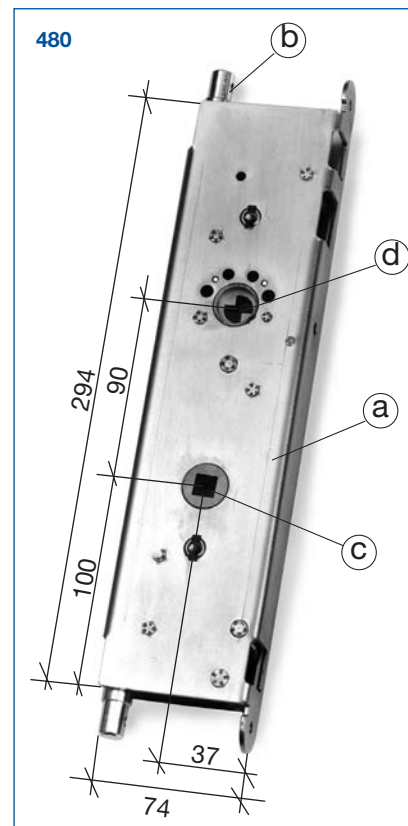
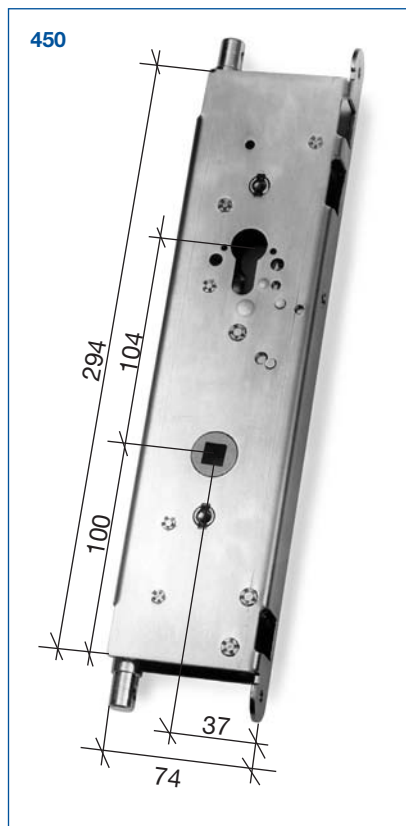
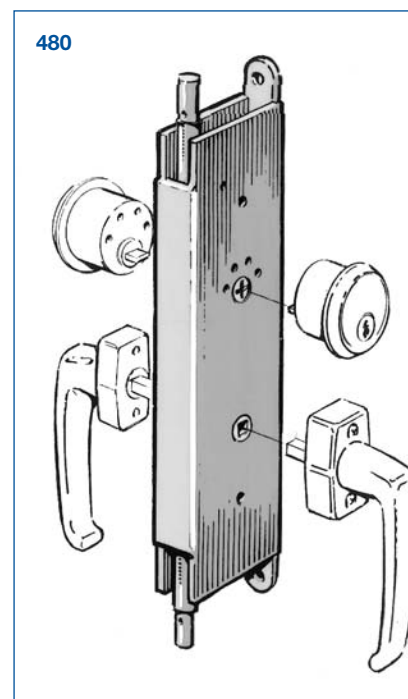
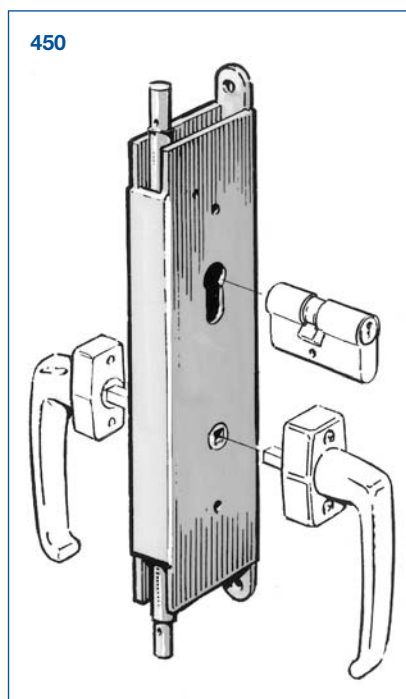

Gate lock

Fix 485

Used for gates, which are operated from both sides. Lockable with cylinder.

Operation and features

Two point locking. Bolts, diameter 20 mm. Handle may be mounted on outside, inside or both. Lock housing is built into a steel cassette. Closing is done when the bolts enter the receiver in the receiving part. Locking may be done with cylinder from one side or both.

Travel for each bolt is 25 mm. Handle rower 10 mm square.

Available in right and left versions.

Construction

- Lock housing.
- Lock housing cassette.
- Receiving part.

Material

Lock housing of galvanized steel. Bolts of stainless steel. Rowers of zinc-aluminium. Lock housing cassette and receiving part of galvanized 3 mm steel.

Installation

Surface mounting. Screwed to master gate/slave gate or post. Distance between gate posts 100–125 mm.

Accessories

Handle Fix 1710, page J 191.
Round or oval cylinder of standard type.

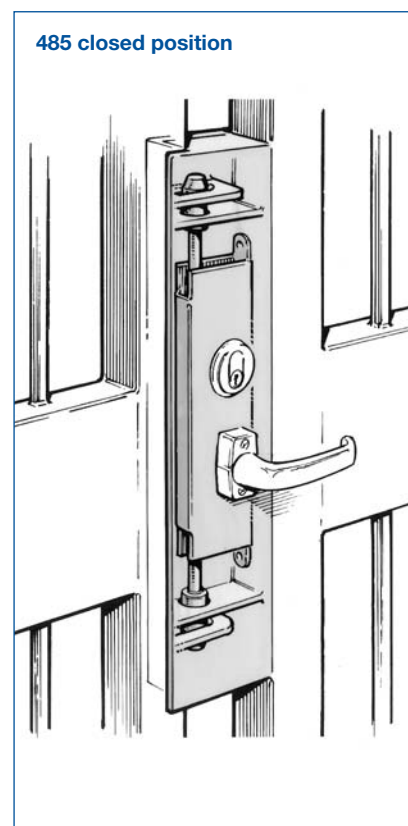
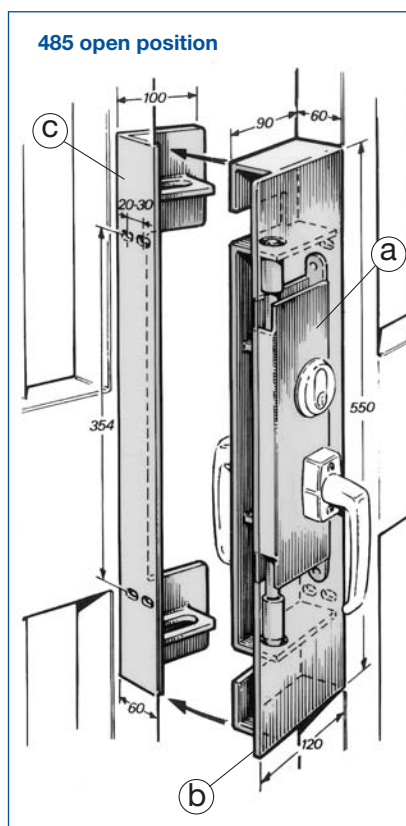

Door holders

Fix 270 and 271

Used for keeping doors in a fully open position, approx. 90 degrees. Max door weight 125 kg.

Fix 270

For door width 800–1100 mm.
Fits both right- and left-hung door (decided when mounting).

Fix 271

For door width 1100–1300 mm.
For right- and left-hung door.

Operation and features

In fully open position (approx. 90 degrees), the catch automatically falls into a locking position and keeps the door in position. When the door is pushed further towards the open position, the catch is released so the door can be closed. The stop spring also works as a shock absorber and thereby reduces wear on door and hinges.

Construction

- a) Frame fixture with stopper arm and stretcher.
- b) Door rail.
- c) Catch.

Material

Steel, galvanized or galvanized and powder painted white.

Installation

Surface mounting. Mounting instructions and screw in the package.

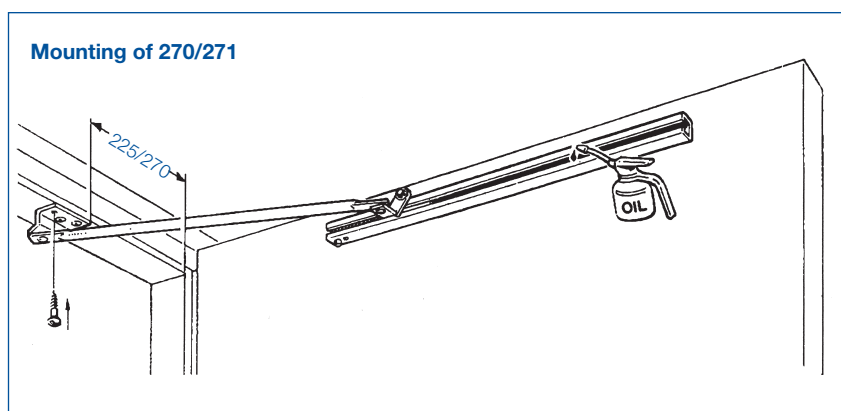
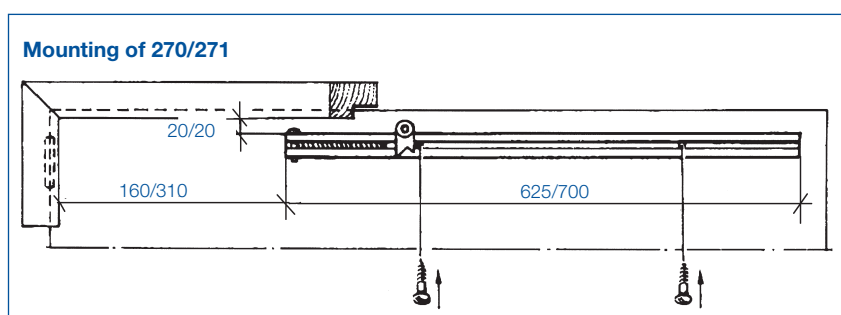
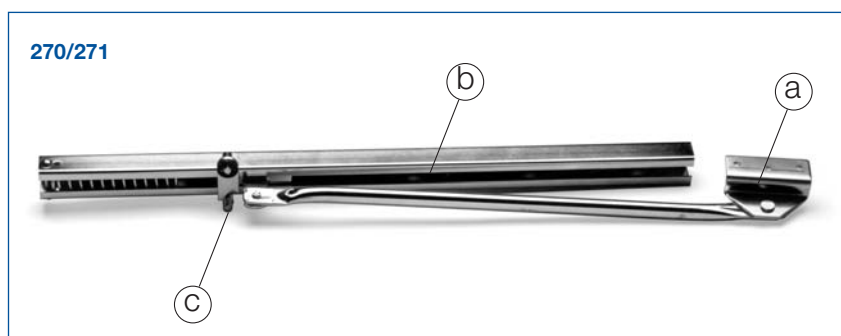
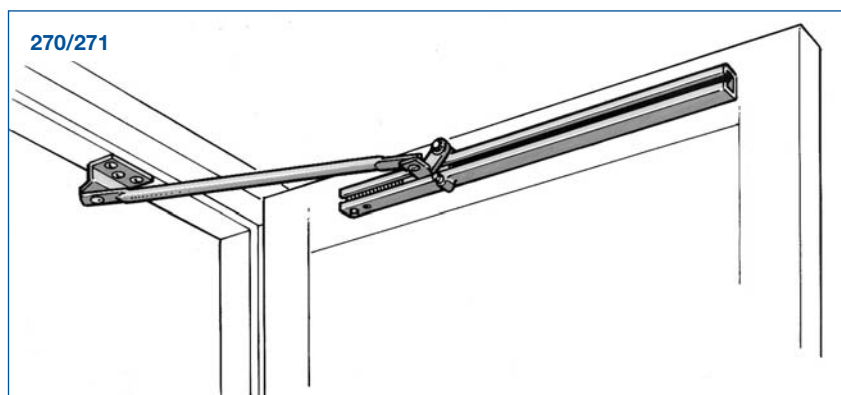

Door holder Fix 580

Used for holding larger or heavier side-hung doors in a fully open position.

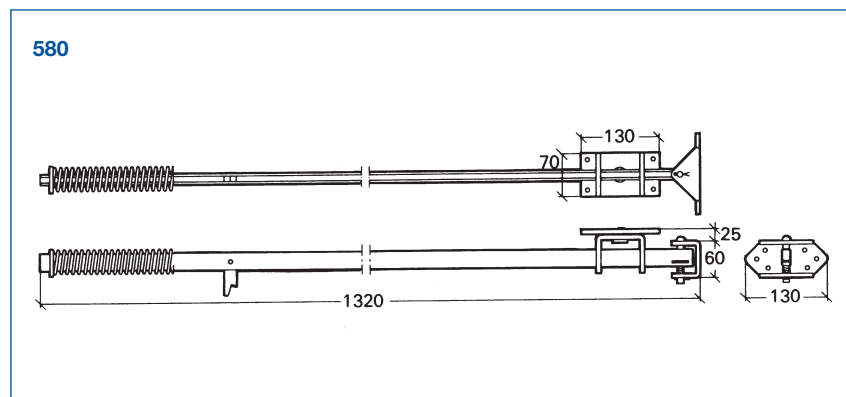
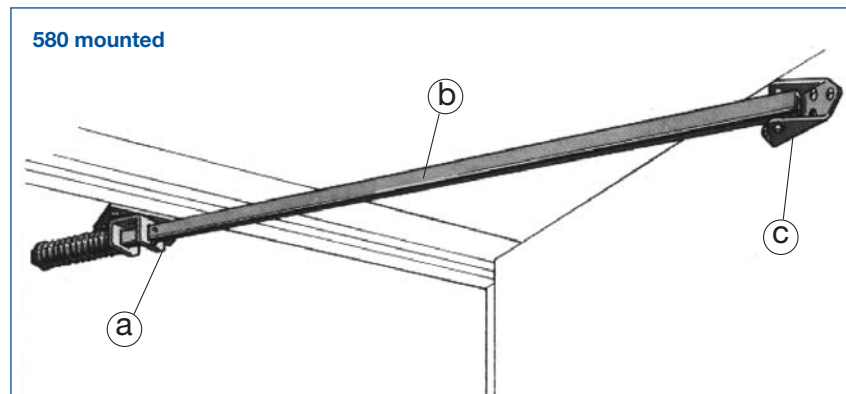

Operation and features

In fully open position (approx. 90 degrees), the catch automatically falls into a locking position and keeps the door in position. When the door is pushed further towards the open position, the catch is released so the door can be closed. The stop spring also works as a shock absorber and thereby reduces wear on door and hinges. Fits both right and left.

Construction

- a) Frame fixture with stretcher.
- b) U profile rod with catch and stop spring.
- c) Door fixture.

Material

Galvanized steel.

Installation

Mounting instructions included in the package.

Screw

Use no. 14 (6.0 mm) TKX / DIN 7996.